

Parcel ID: 000210 000039 000015 (CARD 1 of 1)  
 Owner: OVERBECK, SCOTT D. & SHELBY A.  
 HOLKA, NANCY L.  
 Location: 16 RUNAWAY RD  
 Acres: 2.020

**General**

Valuation		Listing History		Districts	
<b>Building Value:</b>	\$725,400	<u>List Date</u>	<u>Lister</u>	<u>District</u>	<u>% In Dist.</u>
<b>Features:</b>	\$27,600	03/01/2022	RWX	WATER/SEWER	0
<b>Taxable Land:</b>	\$288,200	03/03/2020	RWX	SEWER ONLY	0
<hr/>		01/09/2020	BJLX	WATER ONLY	0
<b>Card Value:</b>	\$1,041,200 	04/03/2018	MMX		
<b>Parcel Value:</b>	\$1,041,200	03/04/2013	RWX		
<a href="#">Review and Pay Property Taxes Online</a>					

**Notes:** GREEN; 3/02 HOUSE 100% COMPLETE PDAS 07/06 POOL UNDER CONSTRUCTION PER INVENTORY CHK 07 07/07 POOL 100% JAR.N/C FRR 10/08 10/25/11- SCREEN PORCH 16X16 & ADDITION 12X24 AT REAR. 4/12 W/O ADD'N 100%, NEW KIT, SPF, DECK, FIN BMSMT AND P/U SHED RW 3/14 EST DORMER 100% RW 5/7/19 ADD FIN BSMNT INLAW PER INVENTORY RW 3/20 OUTDOOR KIT 100% RW 3/22 REPALCE DOOR NVC RW

**History Of Taxable Values**

Tax Year	Building	Features	Land	Value Method	Total Taxable
2024	\$725,400	\$27,600	\$288,200	Cost Valuation	\$1,041,200
2023	\$725,400	\$27,600	\$288,200	Cost Valuation	\$1,041,200
2022	\$438,500	\$23,900	\$227,700	Cost Valuation	\$690,100
2021	\$438,500	\$23,900	\$227,700	Cost Valuation	\$690,100
2020	\$438,500	\$23,900	\$227,700	Cost Valuation	\$690,100
2019	\$438,500	\$21,400	\$227,700	Cost Valuation	\$687,600
2018	\$433,100	\$21,400	\$227,700	Cost Valuation	\$682,200
2017	\$331,800	\$21,400	\$227,600	Cost Valuation	\$580,800
2016	\$331,800	\$21,400	\$227,600	Cost Valuation	\$580,800
2015	\$331,800	\$21,400	\$227,600	Cost Valuation	\$580,800
2014	\$331,800	\$21,400	\$227,600	Cost Valuation	\$580,800
2013	\$296,600	\$21,400	\$227,600	Cost Valuation	\$545,600
2012	\$306,000	\$21,400	\$253,600	Cost Valuation	\$581,000
2011	\$287,200	\$20,000	\$253,600	Cost Valuation	\$560,800
2010	\$287,200	\$20,000	\$253,600	Cost Valuation	\$560,800
2009	\$287,200	\$20,000	\$253,600	Cost Valuation	\$560,800
2008	\$287,200	\$20,000	\$253,600	Cost Valuation	\$560,800
2007	\$324,200	\$20,000	\$169,100	Cost Valuation	\$513,300
2006	\$324,200	\$3,000	\$169,100	Cost Valuation	\$496,300

Sale Date	Sale Type	Qualified	Sale Price	Grantor	Book	Page
11/21/2017	IMPROVED	YES	\$665,000	DIVINCENZO, JONATHAN PETER	5873	0410
11/21/2017	IMPROVED	YES	\$665,000	NATIONAL RESIDENTIAL NOMINEE SERVICES	5873	0413
07/07/2017	IMPROVED	NO - < 100 % INT TRANSFER	\$290,400	KEATING, KATHRYN	5833	2816
11/16/2016	IMPROVED	YES	\$635,000	MASIELLO, MARTHA B., TRUSTEE	5773	1970
12/23/2008	IMPROVED	NO - FAMILY/RELAT GRNTR/E	\$0	MASIELLO, MARTHA B., T	4969	1295
05/27/2004	IMPROVED	YES	\$500,000	PAUL BASSETT	4300	2083
12/03/2001	IMPROVED	YES	\$425,800	NEWFIELDS LAND DEVE	3683	2869

## Land

<b>Size:</b>	2.020 Ac.	<b>Site:</b>	AVERAGE
<b>Zone:</b>	02 - RA - RESID/AGRICUL	<b>Driveway:</b>	PAVED
<b>Neighborhood:</b>	AVERAGE +20	<b>Road:</b>	PAVED
<b>Land Use:</b>	2F RES	<b>Taxable Value:</b>	\$288,200

Land Type	Units	Base Rate	NC	Adj	Site	Road	Dway	Topo	Cond	Ad Valorem	SPI	R	Tax Value	Notes
2F RES	2.000 AC	240,000	H	120	100	100	100	100	100	288,000	0	N	288,000	IN LAW IN BSMNT
2F RES	0.020 AC	10,000	X	100	0	0	0	100	100	200	0	N	200	

## Building

### 2.75 STORY FRAME COLONIAL Built In 2001

<b>Roof:</b>	GABLE HIP ASPHALT	<b>Bedrooms:</b>	4	<b>Quality:</b>	AVG+30
<b>Exterior:</b>	CLAP BOARD	<b>Bathrooms:</b>	5.0	<b>Size Adj.</b>	0.8630
<b>Interior:</b>	DRYWALL	<b>Fixtures:</b>	0	<b>Base Rate:</b>	166.00
<b>Flooring:</b>	HARDWOOD CARPET	<b>Extra Kitchens:</b>	1	<b>Building Rate:</b>	1.1093
<b>Heat:</b>	OIL FA DUCTED	<b>Fireplaces:</b>	0	<b>Sq. Foot Cost:</b>	184.15
		<b>Generators:</b>	0	<b>Effective Area:</b>	4,426
		<b>AC:</b>	YES 100%	<b>Gross Living Area:</b>	3,728
				<b>Cost New:</b>	\$815,048

### Depreciation

Normal GOOD	Physical	Functional	Economic	Temporary	Total Dpr.	Assessment
11%	0%	0%	0%	0%	11%	\$725,400

## Features

Feature Type	Units	Length x Width	Size Adj	Rate	Cond	Value	Notes
SHED-WOOD	120	12 x 10	193	8.00	100	\$1,853	
FIREPLACE 2-1	1		100	4500.00	100	\$4,500	
KITCHEN OS	1		100	2500.00	100	\$2,500	OUTSIDE
IN GRND POOL/GUNITE	684	18 x 38	83	33.00	100	\$18,735	
				<b>Total:</b>		<b>\$27,600</b>	

## Photo





**Sketch**

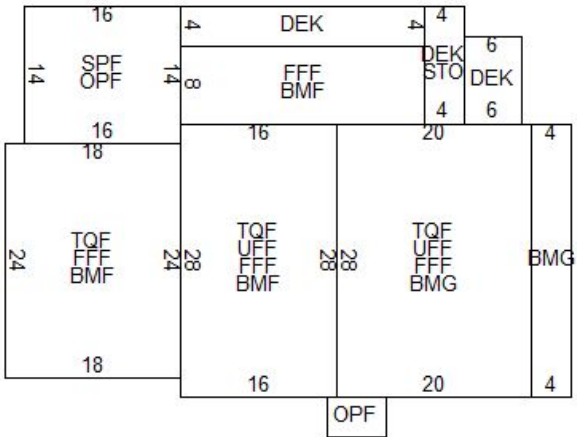

Code	Description	Area	Eff Area	GL Area
BMG	BSMNT GARAGE	672	168	0
UFF	UPPER FLR FIN	1,008	1,008	1,008
TQF	3/4 STRY FIN	1,440	1,080	1,080
FFF	FST FLR FIN	1,640	1,640	1,640
BMF	BSMNT FINISHED	1,080	324	0
OPF	OPEN PORCH FIN	248	62	0
SPF	SCREEN PORCH	224	112	0
DEK	DECK/ENTRANCE	202	20	0
STO	STORAGE AREA	48	12	0
<b>Totals</b>			<b>4,426</b>	<b>3,728</b>