

Print Now

Parcel ID: 000011 000005 000000 (CARD 1 of 1)  
 Owner: PREECE, MICHAEL JAMES  
 PREECE, ASHLEY JEAN  
 Location: 35 WINTERBERRY LANE  
 Acres: 1.940

**General**

Valuation		Listing History	
<b>Building Value:</b>	\$595,700	<u>List Date</u>	<u>Lister</u>
<b>Features:</b>	\$9,500	06/19/2018	JJUM
<b>Taxable Land:</b>	\$454,200	04/30/2015	JJPM
<hr/>		01/10/2003	LTRL
<b>Card Value:</b>	\$1,059,400	05/28/2002	VMRM
<b>Parcel Value:</b>	\$1,059,400	07/18/2000	ALPR
<a href="#">Review Property Taxes Online</a>			

**Notes:** (OLD MAP 4-28-13) D-27549; 2008 CONVERT EXISTING GARAGE TO LIVING AREA & ADD NEW GARAGE; 2015 GENERATOR

**Sales**

Sale Date	Sale Type	Qualified	Sale Price	Grantor	Book	Page
12/21/2022	IMPROVED	YES	\$950,000	RILEY-SCERBO TRUST	6459	1786
04/22/2015	IMPROVED	NO - NONMKT TRUST GRNTR/E	\$0	SCERBO, CATHLEEN RILEY	5611	0172
02/29/2000	VACANT	YES	\$95,000	SANDY BROOK CORP	3458	89
02/25/2000	VACANT	YES	\$56,000	EVAN REALTY TRUST	3457	1597

**Land**

**Size:** 1.940 Ac.      **Site:**  
**Zone:** 01 - RA RES/AGRI      **Driveway:**  
**Neighborhood:** AVERAGE+30      **Road:**  
**Land Use:** 1F RES      **Taxable Value:** \$454,200

Land Type	Units	Base Rate	NC	Adj	Site	Road	Dway	Topo	Cond	Ad Valorem	SPI	R	Tax Value	Notes
1F RES	1.940 AC	349,400	H	130	100	100	100	100	100	454,200	0	N	454,200	

**Building**

**2.50 STORY FRAME COLONIAL Built In 2000**

<b>Roof:</b>	GABLE OR HIP ASPHALT	<b>Bedrooms:</b>	4	<b>Quality:</b>	GOOD+10
<b>Exterior:</b>	VINYL SIDING	<b>Bathrooms:</b>	2.5	<b>Size Adj.</b>	0.9111
<b>Interior:</b>	DRYWALL	<b>Fixtures:</b>	0	<b>Base Rate:</b>	129.00
<b>Flooring:</b>	CARPET LINOLEUM OR SIM	<b>Extra Kitchens:</b>	0	<b>Building Rate:</b>	1.2250
<b>Heat:</b>	OIL HOT WATER	<b>Fireplaces:</b>	0	<b>Sq. Foot Cost:</b>	158.03
		<b>Generators:</b>	0	<b>Effective Area:</b>	4,053
		<b>AC:</b>	NO	<b>Gross Living Area:</b>	3,182
				<b>Cost New:</b>	\$640,496

Depreciation						
Normal	Physical	Functional	Economic	Temporary	Total Dpr.	Assessment
VERY GOOD						
7%	0%	0%	0%	0%	7%	\$595,700

**Features**

Feature Type	Units	Length x Width	Size Adj	Rate	Cond	Value	Notes
FIREPLACE 1-STAND	2		100	3000.00	100	\$6,000	
GENERATOR	1		100	3500.00	100	\$3,500	
<b>Total:</b>						<b>\$9,500</b>	

**Photo**



**Sketch**

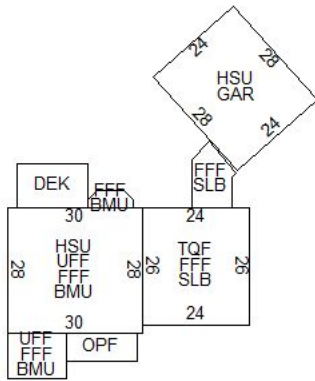

Code	Description	Area	Eff Area	GL Area
DEK	DECK/ENTRANCE	160	16	0
OPF	OPEN PORCH FIN	96	24	0
SLB	SLAB FOUNDATION	738		0
GAR	GARAGE ATTACHED	672	302	0
HSU	1/2 STRY UNFIN	1,512	378	0
UFF	UPPER FLR FIN	970	970	970
FFF	FST FLR FIN	1,744	1,744	1,744
TQF	3/4 STRY FIN	624	468	468
BMU	BSMNT UNFINISHED	1,006	151	0
<b>Totals</b>			<b>4,053</b>	<b>3,182</b>

Printed on 03-06-26