

**Private Sector Repair Permit 32.1-163.5**

April 30, 2025

**Onsite Sewage System Repair Permit - Va. Code §32.1-163.5**

Scott & Cathy Brown  
1924 Custis Mill Pond Rd.  
West Point, VA 23181

RE: 1924 Custis Mill Pond Rd. West Point, VA 23181  
Tax Map/GPIN: 56-1-10 HDID: 150-25-0034  
County: KING WILLIAM/101  
Permit ID: 101-STS-112291  
System Capacity: Residential, 4 Bedrooms, 600 gallons per day  
Occupancy Limit: 8 persons maximum

Dear Scott & Cathy Brown:

This letter and the attached drawings, specifications, and calculations (21 pages) dated 04/23/2025, constitute your permit to repair your sewage disposal system. Your application for a permit was submitted pursuant to §32.1-163.5 of the Code of Virginia, which requires the Health Department to accept private soil evaluations and designs from an Onsite Soil Evaluator (OSE) or a Professional Engineer (PE). VDH is not required to perform a field check to verify the private evaluations of OSEs or PEs and such a field check may not have been conducted for the issuance of this permit.

The soil absorption area ("site"), sewage system design were certified by John Ewing Private OSE as substantially complying with the Board of Health's regulations. This permit is issued in reliance upon that certification. VDH hereby recognizes that the soil and site conditions acknowledged by this permit are suitable for the installation of an onsite sewage system. The attached plat shows the approved area for the sewage disposal system; there are additional records on file with the King William County Health Department pertaining to this permit, including the Site and Soil Evaluation Report. This repair permit is null and void if any substantial physical change in the soil or site conditions occurs where a sewage disposal system is to be located.

If modifications or revisions are necessary, please contact the OSE/PE who performed the evaluation and design on which this permit is based. Should revisions be necessary during construction, your contractor should consult with the OSE/PE that submitted the site evaluation or site evaluation and design. The OSE/PE is authorized to make minor adjustments in the location or design of the system at the time of construction provided adequate documentation is provided to the King William County Health Department. The OSE/PE that submitted the certified design for this permit is required to conduct a final inspection of this sewage system when it is installed and to submit an inspection report and completion statement. As the owner, you are responsible for giving reasonable notice to the OSE/PE of the need for a final inspection. No part of this installation shall be covered until it has been inspected by the OSE/PE as noted herein. The sewage system may not be placed into operation until you have obtained an Operation Permit from the King William County Health Department.

This Repair Permit is null and void if conditions are changed from those shown on your application or if conditions are changed from those shown on the Site and Soil Evaluation Report and the attached construction drawings, specifications, and calculations. VDH may revoke or modify any permit if, at a later date, it finds that the site and soil conditions and/or design do not substantially comply with the Sewage Handling and Disposal Regulations, 12 VAC 5-610-20 et seq., or if the system would threaten public health or the environment.

This permit approval has been issued in accordance with applicable regulations based on the information and materials provided at the time of application. There may be other local, state, or federal laws or regulations that apply to the proposed construction of this onsite sewage system. The owner is responsible at all times for complying with all applicable local, state, and federal laws and regulations. This construction permit is transferrable until expired or deemed null and void. A permit transfer form may be found on the VDH website at <http://www.vdh.virginia.gov/environmental-health/gmp-2015-01-forms/>. If you have any questions, please contact me.

This permit expires: 10/30/2026.

Sincerely,



Samantha Romero EHS

CC: John Ewing Private OSE

Well and Sewage Contractors: Please notify Health Department and OSE or PE 48 hours prior to installation to arrange for inspection.

**WHAT YOU WILL NEED TO GET YOUR SEPTIC SYSTEM OPERATION PERMIT**

Your system must have a satisfactory inspection at the time of installation. This will be done by a private OSE or a PE, depending on the designer of your permitted system. Your OSE or PE must submit a copy of the inspection results, complete with an as-built diagram, to the Health Department.

Please ensure that your contractor turns in a Completion Statement to the local Health Department after installation.

If your permit is for an alternative system, you must sign, have notarized, and record the attached Notice of Recordation in your locality's land records. Please bring proof of this recordation to the local Health Department

If you have a conditional permit then you must sign, have notarized, and record the permit in your locality's land records. Please bring proof of this recordation to the Health Department.

# Commonwealth of Virginia

VDH Use Only  
Health Department ID# 150-25-0034  
Due Date 5/20/25

Application for:  Sewage System  Water Supply

Owner Scott & Cathy Brown

Phone 706-308-6075

Mailing Address 1924 Custis Millpond Rd  
West Point VA 23181

Phone \_\_\_\_\_

Email: sbrown01@uga.edu

Agent SepTech, Inc

Phone 804-874-3474

Mailing Address PO Box 2482

Phone \_\_\_\_\_

Mechanicsville VA 23116

Fax \_\_\_\_\_

Site Address 1924 Custis Millpond Rd

Email Septechva@gmail.com

Directions to Property: Rt. 30; Wakema Rd; Custis Millpond Rd

Subdivision Foxes Reach

Section \_\_\_\_\_ Block \_\_\_\_\_ Lot 10

Tax Map 56-1-10

Other Property Identification \_\_\_\_\_

Dimension/Acreage of Property 27.58

## Sewage System

**Types of Approval:** Applicants for new construction are advised to apply for a certification letter to determine if land is suitable for a sewage system and to apply for a construction permit (valid for 18 months) only when ready to build.

Certification Letter  Construction Permit  Voluntary Upgrade  Repair Permit  Minor Modification

### Proposed Use:

Single Family Home ( Number of Bedrooms 4 )  Multi-Family Dwellings ( Total Number of Bedroom \_\_\_\_\_ )

Other (describe) \_\_\_\_\_

Basement?  Yes  No Walkout Basement?  Yes  No Fixtures in Basement?  Yes  No

Conditional permit desired?  Yes  No If yes, which condition do you want?

Reduced water flow  Limited occupancy  Intermittent of seasonal use  Temporary use not to exceed 1 year

Do you wish to apply for a betterment loan eligibility letter?  Yes  No \*There is a \$50 fee for determination of eligibility.

## Water Supply

Will the water supply be  Public or  Private? Is the water supply  Existing or  Proposed?

If proposed, is this a replacement well?  Yes  No. Will the old well be abandoned?  Yes  No.

Will any buildings within 50' of the proposed well be termite treated?  Yes  No.

Well Type (e.g. domestic use, agricultural, irrigation, etc.) \_\_\_\_\_

## All Applicants

All Applications must be accompanied by private sector evaluations and designs, unless a petition for VDH services is approved.

Is a petition for Service form attached?  Yes  NO

Is this property indeed to serve as your (owners) principle place of residence?  Yes  No

In order for VDH to process your application for a sewage system you must attach a plat of the property and a site sketch. For water supplies, a plat of the property is recommended and a site sketch is required. The site sketch should show your property lines, actual and/or proposed buildings and the desired location of you well and/or sewage system. When the site evaluation is conducted the property lines, building location and the proposed well and sewage sites must be clearly marked and the property sufficiently visible to see the topography.

I give permission to the Virginia Department of Health to enter onto the property described during normal business hours for the purpose of processing this application and to perform quality assurance check of evaluations and designs certified by a private sector Onsite Soil Evaluator or Professional Engineer as necessary until the sewage disposal system and/or private water supply has been constructed and approved.

Scott Brown

Signature of Owner/Agent

4-28-25

Date

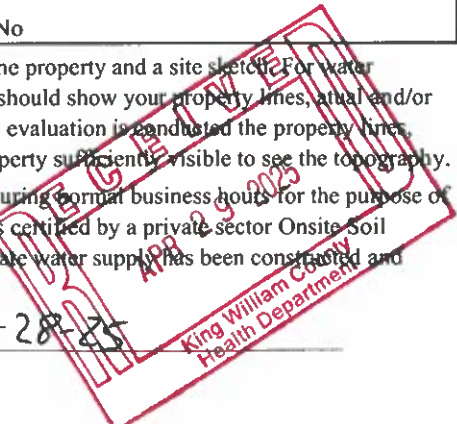

**REQUEST FOR A WAIVER TO THE SURVEY REQUIREMENT**  
(TO BE COMPLETED BY THE OWNER)

Owner's Name Scott Brown  
Owner's Address 1924 Custis Millpond Rd West Point VA  
Owner's Telephone Number 708-308-8075  
Property Location 1924 Custis Millpond Rd Health Department Identification Number \_\_\_\_\_

1. Yes  No  Is a complete site sketch provided with your application showing the property dimensions, all proposed and/or existing structures, driveways, underground and overhead utilities on the property, adjacent sewage disposal systems, bodies of water, drainage ways, agricultural drain tiles, wells, cisterns, and springs for a minimum of 200 feet radius of the proposed building and/or drain field?
2.  ~~Yes~~ ~~No~~ Have you clearly marked the property boundaries? *Boundaries marked by surveyor in 2022. Never ordered a plat.*
3. Yes  No  Have you clearly marked the proposed building or buildings?
4. Yes  No  Are there any permanent structures within 200 feet of the proposed drain field?
5. Yes  No  Does your parcel of land consist of a single lot?
6. Yes  No  Is your parcel of land directly influenced by the off site location of any sewage disposal system, well and/or body of water?
7. Yes  No  Is your application for an onsite sewage disposal system construction permit to repair or replace a malfunctioning system serving a single family or duplex residential dwelling?
8. Yes  No  Is your application for an onsite sewage disposal system construction permit to expand an existing system serving a single family or duplex residential dwelling?
9. Yes  No  Is your proposed building and/or proposed drain field located within 200 feet of a property line?
10. Yes  No  Does a survey plat exist for your property?
11. Yes  No  Does the survey plat requirement pose an undue hardship upon you?  
If yes, explain: Proposed work well with-in property limits. A survey is expensive and not necessary *(as boundaries marked and are not near this project.)*
12. Yes  No  Do you understand that a certification statement shall be signed by you verifying the sewage disposal system is located on your property as permitted prior to issuance of an operation permit?

In all cases, it shall be the landowner's responsibility to ensure that the system is properly located as permitted.

Owner's Signature Scott Brown Date 4-29-25

\*\*\*\*\*

**VDH USE ONLY**

Waiver: Granted (circle one) Date 4-30-25  
Health Department Identification Number \_\_\_\_\_  
Reason(s) for denial of waiver \_\_\_\_\_

Environmental Health Specialist Senior's Signature J. P. [Signature]  
Environmental Health Supervisor's Signature OK by [Signature], waiver not needed.

SepTech, Inc  
 PO Box 2482 Mechanicsville VA 23116  
**OSE/PE Report for**

**Construction Permit**

**Property Location:**  
 911 Address: 1924 Custis Millpond Rd City: West Point  
 Lot 10 Section \_\_\_\_\_ Subdivision Foxes Reach  
 GPIN or Tax Map # TM 56-1-10 Health Dept. ID# \_\_\_\_\_  
 Latitude \_\_\_\_\_ Longitude \_\_\_\_\_

**Applicant or Client Mailing Address:**  
 Name: Scott & Cathy Brown  
 Street: 1924 Custis Millpond Rd  
 City, State, Zip Code: West Point, VA 23181

**Prepared by:**  
 OSE Name John Ewing License # 1940001024  
 Address PO Box 2482  
 City, State, Zip Code Mechanicsville, VA 23116  
 PE Name \_\_\_\_\_ License # \_\_\_\_\_  
 Address \_\_\_\_\_  
 City, State, Zip Code \_\_\_\_\_

Date of Report: **April 23, 2025** Date of revision #: \_\_\_\_\_  
 AOSE/PE Job Number: 25-050E Date of Revision #2 \_\_\_\_\_

**Contents/Index of this report:**

1. Cover Page	6. Pump Spec. Pg 1	11. Design Calculations	16. SDS Operation Permit
2. Construction Drawing	7. Pump Spec. Pg 2	12. Site Sketch	17. GeoThermal Wells (VDH Records)
3. Construction Specs	8. Construction Notes	13. Condition Assessment	18. Control Panel
4. Pump Calculation	9. Tank Regulations	14. Condition Assessment	19. Riser
5. Pump Chamber	10. GIS Map	15. Condition Assessment	20 -21. Lid, Safety Cage

**Certification Statement**  
 I hereby certify that the evaluations and/or designs contained herein were conducted in accordance with the Sewage Handling and Disposal Regulations (12 VAC5-610), the Private Well Regulations (12 VAC5-630), and all other applicable laws, regulations and policies implemented by the Virginia Department of Health. I further certify that I currently possess any professional license required by the laws and regulations of the Commonwealth that have been duly issued by the applicable agency charged with licensure to perform the work contained herein.

The work attached to this cover page has been conducted under an exemption to the practice of engineering, specifically the exemption in **Code of Virginia Section 54.1-402.A.11**

I recommend a **Construction Permit** be **issued**

OSE/PE Signature  Date April 23, 2025

Construction Drawing  
Scott Brown  
1924 Custis Millpond Rd.

Pre-Construction Meeting Required

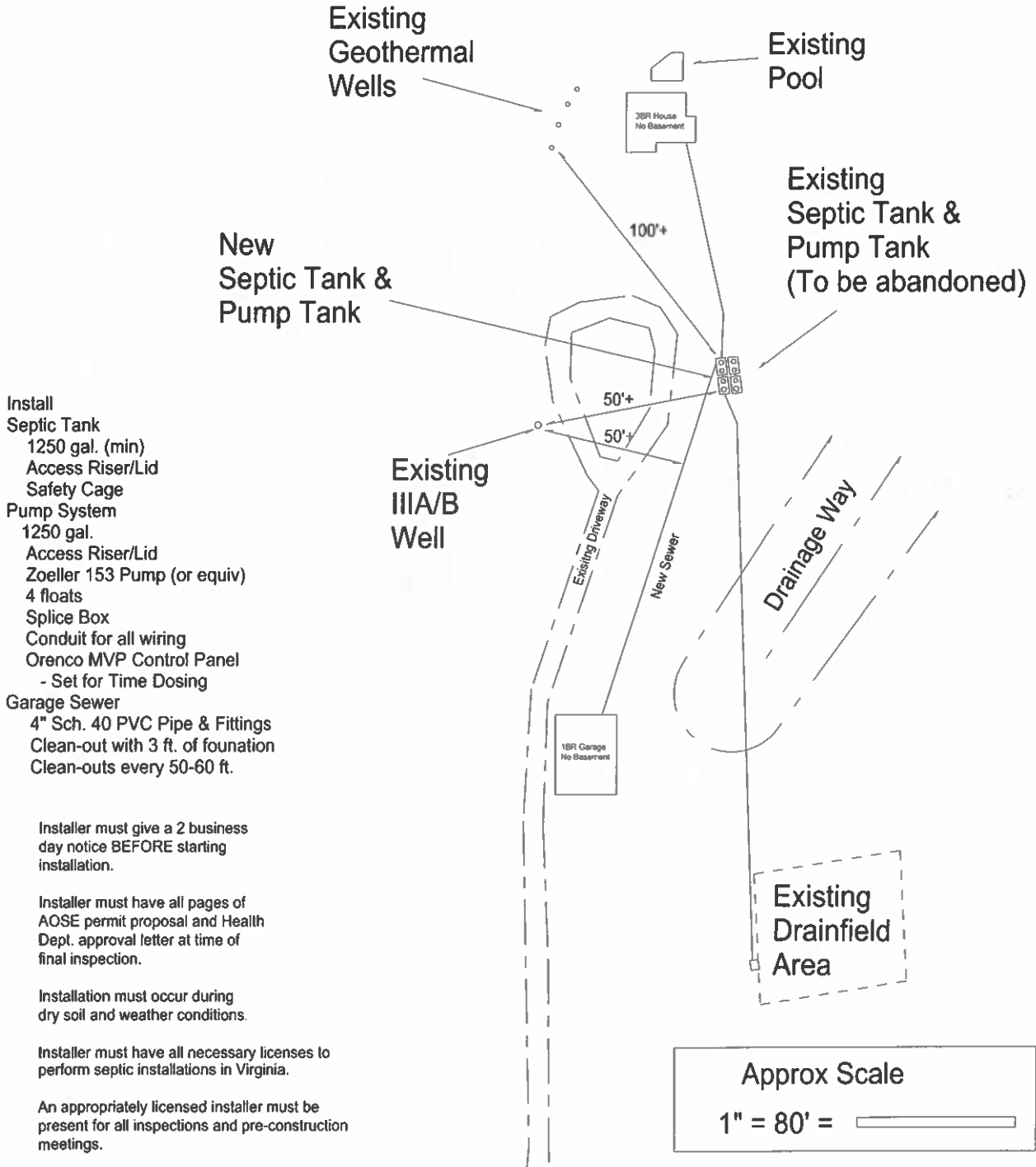

- Install
- Septic Tank
- 1250 gal. (min)
- Access Riser/Lid
- Safety Cage
- Pump System
- 1250 gal.
- Access Riser/Lid
- Zoeller 153 Pump (or equiv)
- 4 floats
- Splice Box
- Conduit for all wiring
- Orengo MVP Control Panel
- Set for Time Dosing
- Garage Sewer
- 4" Sch. 40 PVC Pipe & Fittings
- Clean-out with 3 ft. of foundation
- Clean-outs every 50-60 ft.

Installer must give a 2 business day notice BEFORE starting installation.

Installer must have all pages of AOSE permit proposal and Health Dept. approval letter at time of final inspection.

Installation must occur during dry soil and weather conditions.

Installer must have all necessary licenses to perform septic installations in Virginia.

An appropriately licensed installer must be present for all inspections and pre-construction meetings.

Approx Scale

1" = 80' =

SepTech, Inc. P.O. Box 2482 Mechanicsville, VA 23116 <a href="http://www.septech.net">www.septech.net</a>	John Ewing Master AOSE 1940001024 c. 804-874-3474 e. <a href="mailto:john@septech.net">john@septech.net</a>
--	--

# System Specifications

Property ID: Foxes Reach Lot 10, Scott & Cathy Brown

<b>Applicant Information</b>	
Name <u>Scott &amp; Cathy Brown</u>	Phone <u>706-308-6075</u>
Address <u>1924 Custis Millpond Rd</u> <u>West Point VA 23181</u>	
<b>Location Information</b>	
Tax Map/ GPIN #: <u>56-1-10</u>	Property address <u>1924 Custis Millpond Rd</u>
Subdivision: <u>Foxes Reach</u>	Section: _____ Block: _____ Lot: <u>10</u>
Directions <u>Rt. 30; Wakema Rd; Custis Millpond Rd</u>	
<b>General Information</b>	
System Type <u>Residential</u>	Number of bedrooms <u>4</u>
Daily Flow <u>600 gpd</u>	Conditions <u>none</u>
Notes <u>Existing House = 3 bedrooms; Existing Garage = 1 bedroom</u>	
<b>Sewer Line</b>	
Diameter: <u>4in. Material Sch 40 PVC ( or equivalent)</u>	Notes: <u>Use existing from house; Install new for garage</u>
<b>Pretreatment Unit(s)</b>	
Treatment Level: <u>Septic tank effluent</u>	Septic Tank Capacity: <u>1250</u> gallons
Number of Septic Tanks <u>1</u>	Size of Septic Tank(s) <u>1250</u> gallons
Per the 2000 Sewage Handling & Disposal Regulations, Check which option chosen:	
<input checked="" type="checkbox"/> Septic tank with inspection port <input type="checkbox"/> Septic tank with effluent filter <input type="checkbox"/> Reduced maintenance septic tank	
Secondary Treatment Device(s), if applicable: _____	
Notes: <u>Risers on Septic Tank with secondary safety device.</u>	
<b>Conveyance Line</b>	<b>Distribution Method and Header Lines</b>
Conveyance Method <u>Pump</u>	Distribution Method: <u>D-B (Existing D.box and Surge box)</u>
If pumping, include Pump Specification Sheet.	No. of Boxes: <u>1</u> No. of outlets: <u>8</u>
Material: <u>Sch 40 Pressd</u> Diameter: <u>2"</u>	Surge or splitter box required: <input checked="" type="checkbox"/> Yes <input type="checkbox"/> No
Notes: _____	Header Line Material: <u>4" 1500lb crush strenght plastic or equivalent</u>
<b>Percolation line Information/Absorption Area</b>	
Dispersal Method: <u>Existing Drainfield</u>	
If using pressure dispersal (e.g. Drip), include pressure dispersal specifications sheet.	
No. of Laterals/pads _____	Length of lateral(s)/pad(s): _____ ft. Width of lateral(s)/pad(s): _____ in.
Center to center spacing _____ ft.	Installation depth: _____ in. Aggregate Depth: _____ in.
Size/Type of aggreg _____	Lateral/pad slope: _____ in. per <u>100</u> ft.
Reserve Area Provided: _____	Notes: <u>Existing Drainfield: 8 3 ft. X 75 ft trenches installed in 1990</u>
<b>Please Note:</b>	

AOSE \_\_\_\_\_  \_\_\_\_\_ Date: April 23, 2025

## Pump Calculations

Property ID: Foxes Reach Lot 10, Scott & Cathy Brown

Health Department ID # : \_\_\_\_\_

**Design Basis:**

Trenches: Number: <u>8</u>	Pump Chamber: Size: <u>1250</u> gallons
Length: <u>75</u>	Width: <u>4.5 ft or 54 in</u>
Width: <u>3</u>	Length: <u>9 ft or 108 in</u>
Flow: Bedrooms: <u>4</u>	Gallons per Inch: <u>25</u>
Estimated Gallons per Day: <u>600</u>	
Force Main: Size: <u>2</u>	Number of 90 Degree Bends: <u>3</u>
Total Length: <u>295</u>	Number of 45 Degree Bends: <u>1</u>
Elevation Change: <u>13</u>	
Minimum Design Flow: <u>21 gpm</u>	Maximum Design Flow: <u>78 gpm</u>
<b>System Design Flow: <u>33 gpm</u></b>	On Time: <u>3 min 33 sec</u> Off Time: <u>4 Hrs 41 Min</u>

**Pump Chamber Design Specifications:**

Gallons per cycle: <u>117</u>	Drawdown in inches: <u>4 3/4</u>
Quarter Day Storage in Gallons: <u>150</u>	Quarter Day Storage in inches: <u>6</u>
Minimum Design Flow in GPM: <u>21</u>	Minimum Design Flow : <u>5 minutes 34 seconds</u>
Maximum Design Flow in GPM: <u>78</u>	Maximum Design Flow : <u>1 minutes 30 seconds</u>
System Design Flow in GPM: <u>33</u>	System Design Flow : <u>3 minutes 33 seconds</u>
<u>Simplex System may Be used, System is less than 1,800 Linear Feet</u> <u>Enhanced Flow Not Required</u>	

**Pump Design Specifications at System Design Flow :**

Total Elevation Head: 17 Ft.    Total Friction Loss: 13.08 Ft.    Total Dynamic Head: 30.08 Ft.  
**Pump Model: Zoeller 153** or Equivalent

Projected Pump Curve Data:

GPM	TDH
21	25.95
26	27.48
31	29.28
36	31.35
41	33.69
46	36.27
51	39.11
56	42.20

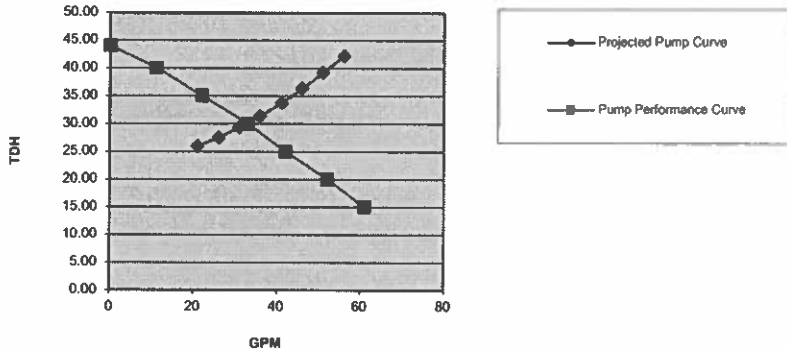

## Pump Chamber Drawing

Property ID: Foxes Reach Lot 10, Scott & Cathy Brown

Pump Chamber Size: 1250 gallons      Pump Model: Zoeller 153 or Equivalent  
 Gallons Per Cycle: 117      Drawdown in Inches: 4 3/4  
 Maximum Pump Cycle Time at System Design of 33 GMP is 3 minutes 33 seconds

- \* Pump Must Provide 33 gpm Minimum at System Head      Off Time: 4 Hrs 41 Min
- \* The Pump Station Must Be Provided with Control for Automatically Starting and Stopping the Pump Based on Water Level
- \* The Electrical Motor Control Center and Master Disconnect Switch Shall Be Placed in a Secure Location Above Grade and Remote From the Pump Station
- \* Each Motor Control Center Shall Be Provided with a Manual Override Switch.
- \* A High Water Alarm With Remote Sensing And Electrical Circuitry Separate From The Motor Control Center Circuitry Shall Be Provided.
- \* The Alarm Shall Be Audiovisual And Shall Alarm In An Area Where It May Be Easily Monitored (Living Area)
- \* All Piping Shall Be Of The Pressure Type With Pressure Fittings That Are Chemically Fused.
- \* Do Not Use Any Compression Fittings. Use Glue Or Screw Fittings Only.
- \* Use An Open Faced Centrifugal Pump Designed To Pump Sewage.
- \* Pump Chamber Must Be Level And Watertight.
- \* Use An Approved Pump Chamber Only.

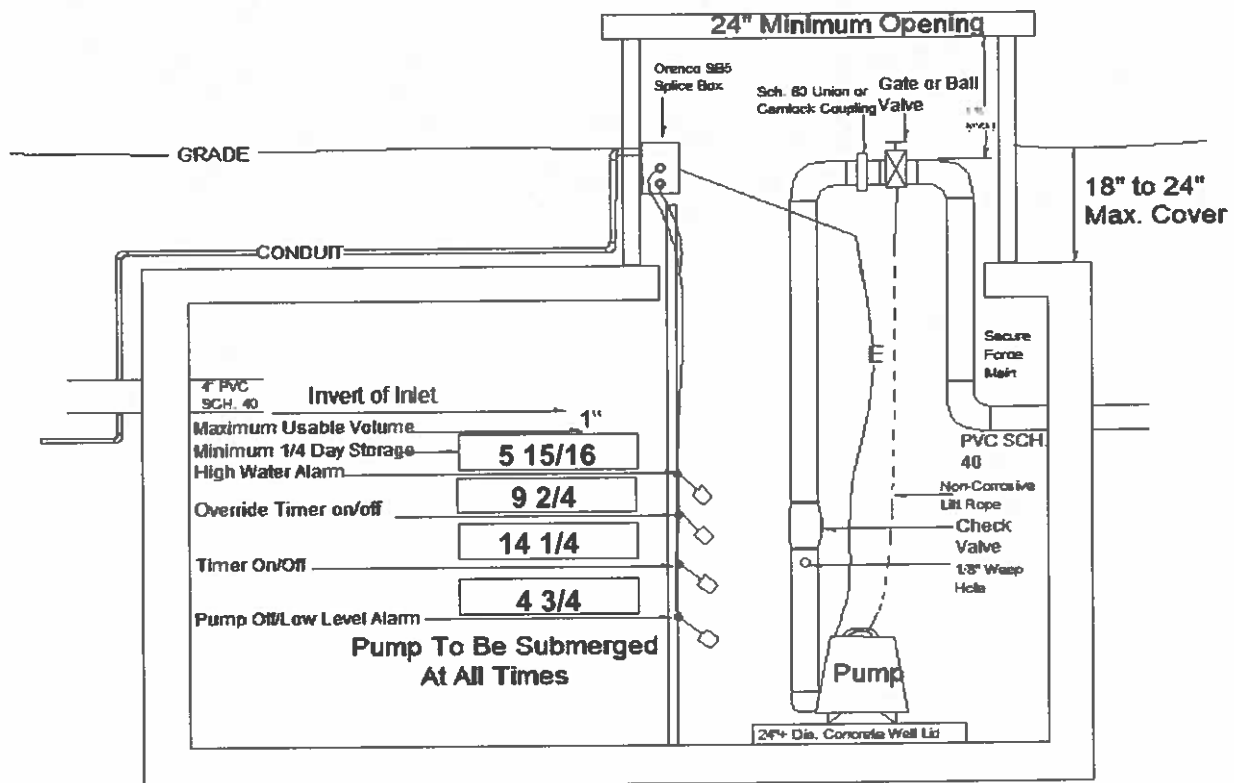

AOSE Job # : 25-050E

Trusted. Tested. Tough.™

Product information presented here reflects conditions at time of publication. Consult factory regarding discrepancies or inconsistencies.



SECTION: 2.15.080  
FM2784  
1017  
Supersedes  
0315

## TECHNICAL DATA SHEET DOSE-MATE SERIES Models 151, 152, 153 Effluent Pumps

### PRODUCT SPECIFICATIONS

<b>MOTOR</b>	Horse Power	1/3 (151), 4/10 (152), 1/2 (153)
	Voltage	115 or 230
	Phase	1 Ph
	Hertz	60 Hz
	RPM	3450
	Type	Permanent split capacitor
	Insulation	Class B
<b>PUMP</b>	Amps	3.0 - 10.5
	Operation	Automatic or nonautomatic
	Discharge Size	1-1/2" NPT
	Solids Handling	1/2" (12 mm), 3/4" (19 mm) spherical solids
	Cord Length	20' (6 m)
	Cord Type	UL listed power cord
	Max. Head	44' (13.4 m)
	Max. Flow Rate	77 GPM (291 LPM)
	Max. Operating Temp.	130 °F (54 °C)
	Cooling	Oil filled
<b>MATERIALS</b>	Motor Protection	Auto reset thermal overload
	Cap	Cast iron
	Motor Housing	Cast iron
	Pump Housing	Cast iron
	Base	Plastic or cast iron
	Upper Bearing	Sleeve bearing
	Lower Bearing	Ball bearing
	Mechanical Seals	Carbon and ceramic
	Impeller Type	Non-clogging vortex
	Impeller	Engineered thermoplastic
	Hardware	Stainless steel
	Motor Shaft	AISI 1215 steel
	Gasket	Neoprene

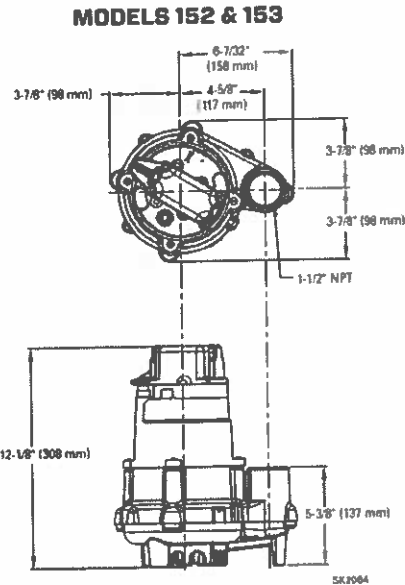
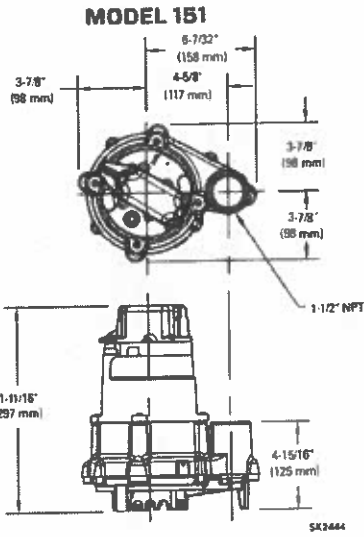

NOTE: The sizing of effluent systems normally requires variable level float(s) controls and properly sized basins to achieve required pumping cycles or dosing timers with nonautomatic pumps.

NOTE: See model comparison chart for specific details.



© Copyright 2017 Zoeller® Co. All rights reserved.  
502-778-2731 | 800-928-7867 | 3649 Cane Run Road | Louisville, KY 40211-1961 | zoellerpumps.com

AOSE Job # : 25-050E

### TOTAL DYNAMIC HEAD FLOW PER MINUTE

MODEL		151		152		153	
Feet	Meters	Gal.	Liters	Gal.	Liters	Gal.	Liters
5	1.5	50	189	69	261	77	291
10	3.0	45	170	61	231	70	265
15	4.6	38	144	53	201	61	231
20	6.1	29	110	44	167	52	197
25	7.6	18	61	34	129	42	159
30	9.1	--	--	23	87	33	125
35	10.7	--	--	--	--	22	85
40	12.2	--	--	--	--	11	42
Shut-off Head:		30 ft. (9.1m)		38 ft. (11.6m)		44 ft. (13.4m)	

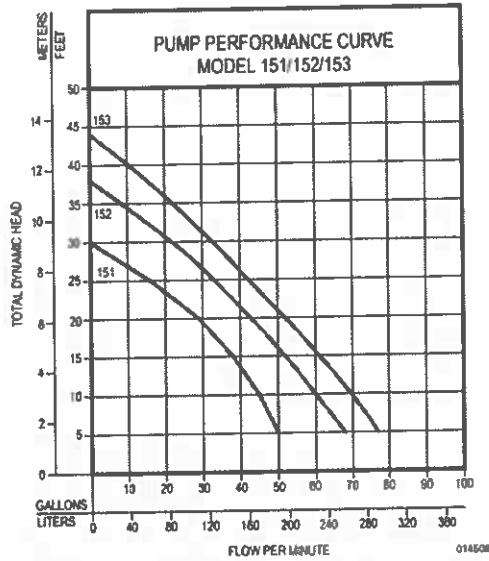

Model	MODEL COMPARISON										Simplex	Duplex
	Seal	Mode	Volts	Ph	Amps	HP	H <sub>z</sub>	Lbs	Kg			
N151	Single	Non	115	1	6.0	1/3	60	32	15	1	2 or 3	
E151	Single	Non	230	1	3.0	1/3	60	32	15	1	2 or 3	
BN151	Single	Auto	115	1	6.0	1/3	60	33	15	*	2 or 3	
BE151	Single	Auto	230	1	3.0	1/3	60	33	15	*	2 or 3	
N152	Single	Non	115	1	8.5	4/10	60	37	17	1	2 or 3	
E152	Single	Non	230	1	4.3	4/10	60	37	17	1	2 or 3	
BN152	Single	Auto	115	1	8.5	4/10	60	39	18	*	2 or 3	
BE152	Single	Non	230	1	4.3	4/10	60	39	18	*	2 or 3	
N153	Single	Non	115	1	10.5	1/2	60	37	17	1	2 or 3	
BN153	Single	Auto	115	1	10.5	1/2	60	39	18	*	2 or 3	
E153	Single	Non	230	1	5.3	1/2	60	37	17	1	2 or 3	
BE153	Single	Non	230	1	5.3	1/2	60	39	18	*	2 or 3	

\*BN and BE models include a 20' (6 m) piggyback variable level pump switch. Additional cord lengths are available in 26' (8 m) and 35' (11 m). 50' (15 m) cords are available for 230 V units only.

NOTE: Model 151 has a plastic base. Models 152 & 153 have a cast iron base.

### SELECTION GUIDE

- For automatic, use single piggyback variable level float switch or double piggyback variable level float switch. Refer to FM0477.
- See FM1228 for correct model of simplex control panel.
- See FM0712 for correct model of duplex control panel.

#### OPTIONAL PUMP STAND P/N 10-2421

- Reduces potential clogging by debris
  - Replaces rocks or bricks under the pump
  - Made of durable, noncorrosive ABS
  - Raises pump 2" (5 cm) off bottom of basin
  - Provides the ability to raise intake by adding sections of 1/2" or 2" (DN40 or DN50) PVC piping
  - Attaches securely to pump
  - Accommodates sump, dewatering and effluent applications
- NOTE: Make sure float is free from obstruction.

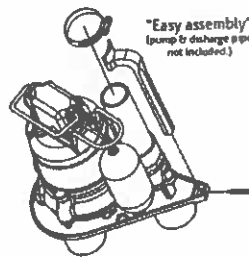

All installation of controls, protection devices and wiring should be done by a qualified licensed electrician. All electrical and safety codes should be followed including the most recent National Electrical Code (NEC) and the Occupational Safety and Health Act (OSHA).

© Copyright 2017 Zoeller® Co. All rights reserved.

502-778-2731 | 800-928-7867 | 3649 Cane Run Road | Louisville, KY 40211-1961 | zoellerpumps.com

AOSE Job # : 25-050E

Property ID: Foxes Reach Lot 10, Scott & Cathy Brown

**Septic System Construction Notes**  
**(Applicants and Installers – Read Carefully!!!)**

- All Federal, State, and Local regulations must be observed when installing this system.
- No buried utility lines shall be closer than 10 feet to any part of this system.
- Installation must follow OSHA codes.
- Do not install drainfield system or clear drainfield area during periods of wet weather or wet soil conditions.
- Land clearing resulting in a significant change of the original grade or soil continuity may result in the revocation of the permit.
- Garbage disposals are not recommended with septic systems unless an additional dedicated grease trap is installed.
- Drainfield trenches shall be placed on contour. Drainfield pads shall be installed level.
- Roof drains, basement sump discharges (non-sewage), floor drains, footing drains, etc., are not allowed to be connected to septic system.
- Divert all roof drain run off and any other surface water flow away from or around drainfield.
- Keep structures and driveways off the drainfield area and reserve area.
- Trees and plants such as weeping willows, maples, gums, and other water loving species should be removed if within 25 feet of drainfield.
- Minimum cover of fill over aggregate is 12 inches, and cover of fill must be crowned in a way that promotes surface drainage away from drainfield area and prevents ponding of water on or around drainfield area.
- After covering drainfield area, immediate seeding and application of straw is required over and around drainfield to prevent erosion. A grass lawn must be maintained above drainfield area.
- This sewage disposal system and/or water supply is to be constructed as specified by the permit, drawing, and the attached specifications. John Ewing AOSE # 1940001024 (804-874-3474) must be notified prior to any changes necessary to the design.
- John Ewing must be notified at least 2 BUSINESS DAYS prior to final inspection.  
 A message left on voicemail after normal business hours, over the weekend or a holiday will not be considered received until the following business day. Voicemail messages must be confirmed in order to establish inspection appointment. Call 804-874-3474 to arrange for this inspection. There is a \$500.00 fee for this inspection.
- All conventional drainfield designs which include a pump for conveying effluent to a drainfield must have a drawdown inspection. There is a \$350 charge for this inspection if it requires an additional trip. However, the septic contractor is responsible for arranging this inspection and preparing the pump chamber for inspection. Please call if there are any questions on how to prepare the pump chamber. This inspection is critical and the completion statement will not be released until a satisfactory inspection of the pump system is conducted.
- The permit will be revoked and the completion statement will not be signed if the septic system is covered before final inspection.
- The completion statement will not be released until payment is received for the system inspection and/or the system design.
- This permit proposal will be void 2 years from the date of its design.
- Any changes to the site or soil conditions of this property will void this permit proposal.
- The performance of any alternative treatment system used in any permit design is not guaranteed by Septech, Inc. Only alternative treatment systems approved by the Virginia Department of Health can be used for onsite septic system designs. Septech, Inc. assumes their performance based on this approval.
- It is the owner's and the contractor's responsibility to ensure that the well, primary drainfield and reserve area are designed and installed on the applicant's property and does not interfere with utilities and easements.

**Pre-Construction Meeting Required**

AOSE Job # : 25-050E

Property ID: Foxes Reach Lot 10, Scott & Cathy Brown

All septic tanks permitted to be constructed after July 1, 2000 shall be designed in accordance to The Sewage Handling and Disposal Regulations, which were effective on that date. (12 VAC 5-610-817 Maintenance)

Options:

1. **Inspection Port.** A three-inch or larger port pipe structure which allows access to the septic tank for the purpose of measuring sludge and scum accumulation. The inspection port shall terminate at or above grade and shall be designed to allow an inspection of sludge buildup in the septic tank. Shall be constructed of schedule 40 PVC or equivalent, and shall be fitted with a watertight treaded cap. The recommended location of the inspection port shall be in or near the manhole cover on the inlet side of the septic tank away from the inlet tee. Other locations may be approved by the district health department on a case-by-case basis.

2. **Effluent Filter.** An effluent filter is a device which has one or more of the following purposes: (i) to manage solids to provide greater service life to a pump or other components of an onsite system; (ii) to manage the total suspended solids (TSS) passed to the absorption field, potentially enhancing absorption field life; or (iii) some other purpose recognized as beneficial to the department.

a) All effluent filters shall improve the quality of the effluent leaving the tank in a manner, which is consistent with their purpose.

b) Septic tank outlet filters shall be constructed from a material, which resist the corrosive nature of the environment within a septic tank.

c) A tamper proof child resistant at-grade port shall be provided to assure the filter can be readily maintained as necessary.

3. **Reduced Maintenance Septic Tanks.** Septic tanks, which are, sized 30% larger than shown in Table 5.3 and which are baffled such that the first compartment is nominally the volume required in Table 5.3 shall be considered to be a reduced maintenance septic tank.

a) Multiple septic tanks in series. The required volume for a septic tank may be satisfied by the utilization of two septic tanks in series; however, the first septic tank in series shall equal  $\frac{1}{2}$  to  $\frac{2}{3}$  the total volume.

**Table 5.3**

Typical Septic Tank Dimensions in Feet.

Approximate Gallons	Length	Width	Liquid Depth	Freeboard
750	7	3.5	4	1
900	8	4	4	1
1200	9	4.5	4	1
1500	9.5	5	4.7	1

OSE Job # : 25-050E

## Design Calculations

 Property ID: Foxes Reach Lot 10, Scott & Cathy Brown

Flow	
Type of use (residential, etc) <u>Residential</u> No. of bedrooms: <u>4</u> No. of employees: _____ Square Footage of building space: _____ Daily flow (peak design) in GPD: <u>600</u>	Show Calculations Here <sup>1</sup>
Treatment	
No. of septic tanks: <u>1</u> Size of septic tank(s): <u>1250</u> Pretreatment required? <input type="checkbox"/> Yes <input checked="" type="checkbox"/> No If yes, specify type of treatment device: _____	Show Calculations Here <sup>1</sup>
Absorption area design	
Soil Texture Group: _____ Reserve area required? <input type="checkbox"/> Yes <input checked="" type="checkbox"/> No <input type="checkbox"/> 50% <input type="checkbox"/> 100% <input type="checkbox"/> other (check one) Specify other	If pump system, enhanced flow, or LPD show calculations here or on a separate sheet. (dosing volume, head, pump design, etc.)
Water Supply	
Class of well: <u>III A/B</u> Distance between septic tank(s) and well: <u>50'+</u> Distance between absorption area and well: <u>50'+</u>	Describe (bored, drilled): <u>Drilled</u> (Existing)

<sup>1</sup> Information and calculations required for commercial and/or conditional use applications only

# 1924 Custis Mill Pond



4/18/2025, 9:20:57 AM

 Parcels

World Imagery

Low Resolution 15m Imagery

High Resolution 60cm Imagery

High Resolution 30cm Imagery

Citations



60cm Resolution Metadata

1:2,638  
0 0.02 0.04 0.07 0.09 mi  
0 0.04 0.07 0.14 km

Maxar, Microsoft

### Site Sketch

Scott Brown  
1924 Custis Millpond Rd.

Existing  
Geothermal  
Wells

Existing  
Pool

Existing  
Septic Tank &  
Pump Tank  
(To be abandoned)

Existing  
III/A/B  
Well

Existing  
Driveway

Drainage  
Way

1BR Garage  
No Basement

Existing  
Drainfield  
Area

Approx Scale  
1" = 80' = 

Schematic drawing of sewage disposal system and topographic features. Show the lot lines of the building lot and building site, sketch of property showing any topographic features which may impact on the design of the system, all existing and/or proposed structures including sewage disposal systems and wells within 200 feet of sewage disposal system and reserve area. The scale drawing of the sewage disposal system shall show , pretreatment unit, pump station, and subsurface soil absorption area, reserve area, etc. When a nonpublic drinking water supply is to be located on the same lot, show all sources of pollution within 200 feet.

SepTech, Inc.  
P.O. Box 2482  
Mechanicsville, VA 23116  
www.septech.net

John Ewing  
Master AOSE 1940001024  
c. 804-874-3474  
e. john@septech.net

Form 14

# Existing System Evaluation

VDH Use Only

HDIN: \_\_\_\_\_

VPDES GP: \_\_\_\_\_

<b>Owner and Application Information</b>	<input type="checkbox"/> Repair	<input checked="" type="checkbox"/> Voluntary Upgrade
Name: <u>Scott &amp; Cathy Brown</u>	Phone Number: <u>706-308-6075</u>	
Address <u>1924 Custis Millpond Rd</u>		
Email <u>sbrown01@uga.edu</u>		

<b>System Location</b>			
Address <u>1924 Custis Millpond Rd</u>			
Tax Map/GPIN # <u>TM 56-1-10</u>			
Subdivision <u>Foxes Reach</u>	Section _____	Block _____	Lot <u>10</u>
Directions <u>Rt. 30; Wakema Rd; Custis Millpond Rd</u>			

<b>System File Information</b>			
Permit Type: <input checked="" type="checkbox"/> Onsite Disposal	<input type="checkbox"/> Stream Discharging System		
Property Type: <u>Residential</u>			
Permitted Design Flow: <u>600</u> gpd	Permitted # Bedrooms: <u>4</u>		
System Type: <input checked="" type="checkbox"/> Conventional	<input type="checkbox"/> Alternative If Alternative, Treatment Mfg. & Model: _____		
Dispersal Method: <input type="checkbox"/> Gravity	<input checked="" type="checkbox"/> Pump to Gravity	<input type="checkbox"/> LPD	<input type="checkbox"/> Drip
Dispersal Media: <input checked="" type="checkbox"/> Gravel	<input type="checkbox"/> Gravelless Material	<input type="checkbox"/> Tire Chips	<input type="checkbox"/> Sand
Gravelless Type _____	Notes _____		
<input checked="" type="checkbox"/> Attach a Copy of the As-built drawing or drawing of the system layout			

<b>Existing System Evaluation</b>			
Failure Observed or reported by owner: <input type="checkbox"/> Yes <input checked="" type="checkbox"/> No: <input type="checkbox"/> Backup into home <input type="checkbox"/> Effluent on ground surface			
If failure observed or reported by owner, <b>Repair permit Required</b>			
Number of Occupants: <u>2</u>		Date System Installed <u>1990</u>	
Current Use <u>Residential</u>		Current Number of Bedroom: <u>4</u>	
Has property been occupied for previous 30 day period? <input checked="" type="checkbox"/> Yes <input type="checkbox"/> No			
Garbage Disposal: <input type="checkbox"/> Yes <input checked="" type="checkbox"/> No		Water Softener <input type="checkbox"/> Yes <input checked="" type="checkbox"/> No	
		Jacuzzi/Hot Tub: <input type="checkbox"/> Yes <input checked="" type="checkbox"/> No	
Date of Last Septic Tank Pump Out: _____		Date of Last Operator Visit _____	
		<u>2025</u>	

<b>Component Status</b> (Please check under appropriate box)					
Component	Present	Inspected	Functional	Non-Functional	Observations/Comments
Sewer Line	X		X		
Septic Tank	X	X	X		Significant Deterioration
Septic Tank Tees	X	X	X		
Treatment Unit					
Pump Chamber	X		X		Significant Deterioration
Pump	X		X		
Disinfection					
Conveyance Line	X		X		

Component	Present	Inspected	Functional	Non-Functional	Observations/Comments
D-Box	X	X	X		
Splitter Manifold					
Header Trench	X		X		
Dispersal Pipe					
Dispersal Media	X	X	X		Augered into existing trench
Dispersal Field	X	X	X		8: 3' x 75' trenches
Other					
Other					

**Additional Analyses**

Analysis	Needed	Conducted	Observations/Comments
Flow			
Wastewater Sample			
Dye Test			
Other			

**Additional Comments and Observations:**

Control panel and wiring in poor condition

Sketch, if applicable:

**Recommended Action** | **Repair**

Identify Probable Cause of Component Malfunction (check all that apply):

- Unknown  Damaged/Compromised  Deterioration  Hydraulic Overload  Organic Overload  
 Improper Maintenance  Root Infiltration

Describe temporary corrective recommended action(s) and purpose of action(s): \_\_\_\_\_

Describe Permanent recommended action(s) and purpose of action(s): \_\_\_\_\_

Replace septic tank and pump tank. Install new control panel, pump, and floats

**Form Completed By:**

Name: John Ewing Signature: \_\_\_\_\_

Date: 4/23/2025

Professional License Type and Number: Master A.O.S.E. 1940001024

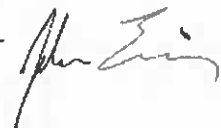

# Sewage Disposal System Operation Permit

Commonwealth of Virginia  
Department of Health



Health Department 150-89-055  
Identification No. King William County Health Department

Tax Map No. 55-43 & 43 A

James and Pam Hembree

is Hereby Granted Permission 600 gpd, at

to Operate a (Type) I Sewage Disposal System Having a Design Capacity of 600 gpd, at East side Rt. 625 approximately .3 mile North of Curtis Pond

SUBDIVISION	SECTION/BLOCK	LOT
Foxes Reach		10

This permit is Issued in Accordance with the Provisions of 32.1, Chapter 6 of the Code of Virginia as Amended and Section(s) 3.14 of the Sewage Handling and Disposal Regulations of the Virginia Department of Health and

with Previously Issued permits CFS 202 B

Dated March 27, 1989

with the understanding that the Owner and/or any Subsequent Owner will operate the Sewage Disposal System in Accordance with the Sewage Handling and Disposal Regulations of the Virginia Department of Health and any Variances or Conditions Granted. Issuance of an Operating Permit does not imply or Guarantee that the Sewage Disposal System will Function for any Specified Period of Time.

VARIANCES GRANTED  
 NONE  SEE ATTACHED

SPECIAL CONDITIONS  
 NONE  SEE ATTACHED

September 21, 1990

*Clyde C. Dearing*  
Recommended (Sanitarian)

*[Signature]*  
Approved (State Health Commissioner)

Effective Date

Approved (State Health Commissioner)



Water Pro Inc. P.O. Box 122, Gloucester, VA 23061  
Ph. (804)-693-7294 Fax: (804)-693-5546

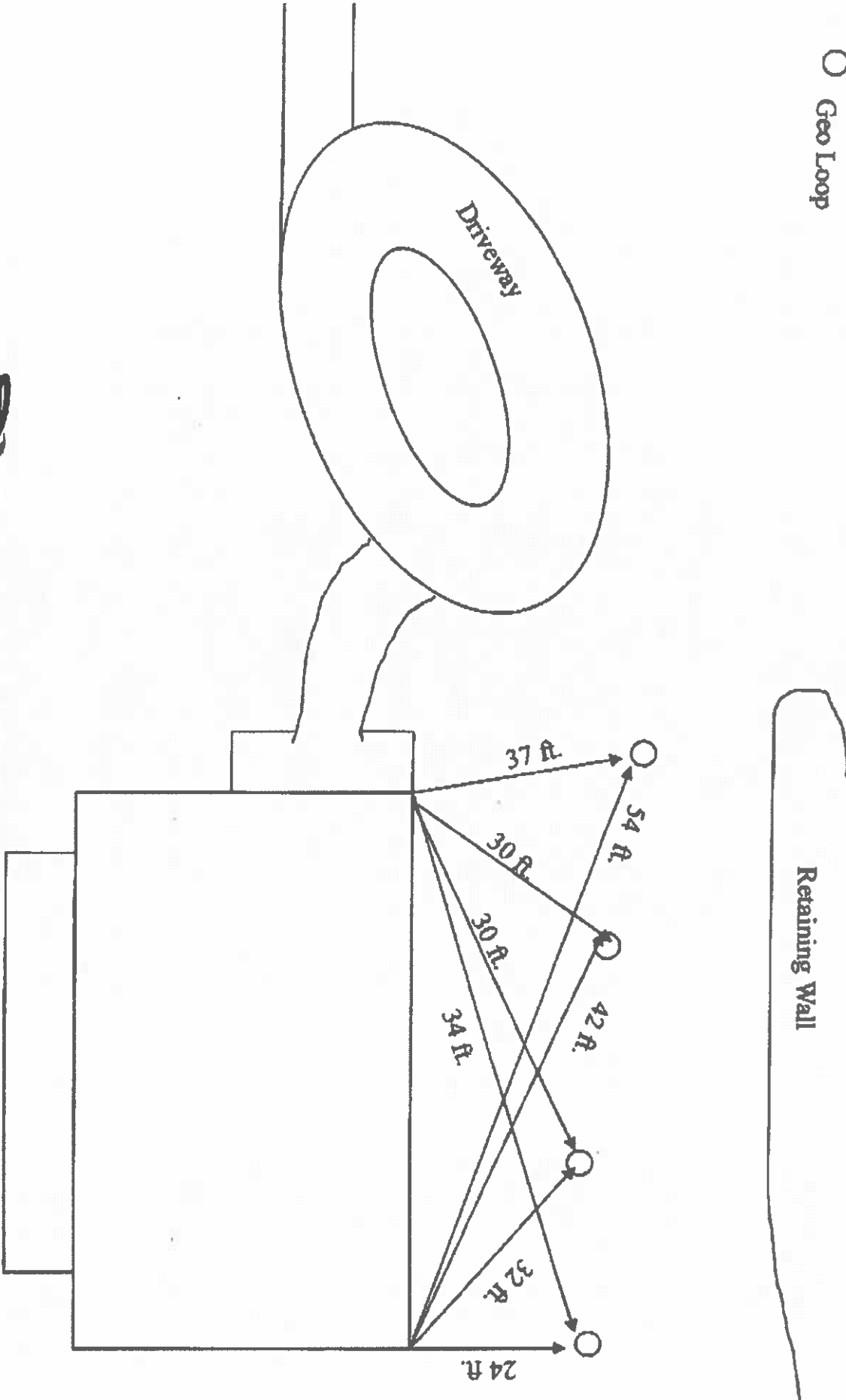

# MVP Simplex Control Panel

## Applications

Orenco® MVP Simplex Control Panels provide timed- or demand-dosing controls for single pumps in onsite septic systems, effluent sewer (STEP) systems, and for pump controls into gravity sewer systems.

All MVP panels include an easy-to-use, programmable logic unit (PLU) that incorporates many timing and logic functions, such as multiple timing intervals to adjust for changing flow conditions and a built-in elapsed time meter and counter.

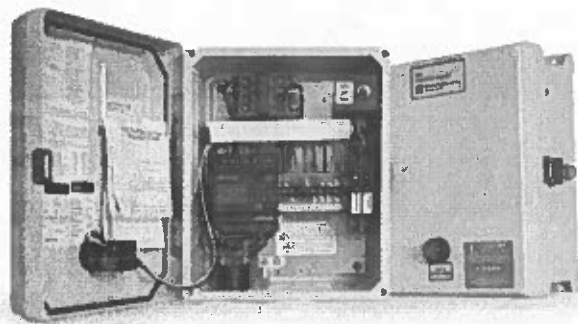

The MVP control panel (MVP-S1DM shown) accommodates both timed- and demand-dosing



The brain of the Orenco® MVP control panel is its programmable logic unit (PLU)



## Materials of Construction

Component	Material
Enclosure	UV-resistant fiberglass, Type 4X (IP 66)
Hinge	Stainless steel
Latch	Stainless steel

## Specifications

Feature	Specifications
Height, in. (mm)	11.5 (292)
Width, in. (mm)	9.3 (236)
Depth, in. (mm)	5.4 (137)
MVP-S1 panel ratings*	120 VAC, 1 hp (0.75 kW), 16 A, 1-phase, 60 Hz
MVP-S2 panel ratings*	120 VAC, 1 hp (0.75 kW), 16 A, 1-phase, 60 Hz or 240 VAC, 3 hp (2.24 kW) 16 A, 1-phase, 60 Hz

\* Pump motors used with these panels require internal overload protection.

## Features/Unique Specifications

To specify this panel for your installation, require the following:

- Programmable for timed- or demand-dosing applications
- Built-in elapsed time meter and counters
- Digital timed-dose function accurate within 1%
- Multiple timer settings for optimum dosing during normal and peak flow conditions
- Built-in programming keys for field-adjustable timer settings without a portable computer
- Ability to use EEPROM card to change panel functions
- High- and low-level alarm conditions differentiated by steady or blinking LED light
- Silenced alarms automatically reactivated after 12 hours if condition is not corrected
- Standard 120 V output for remote alarm activation
- Timed delays on float inputs to prevent chattering
- Ability to use one model of float for all functions
- Visual indicators of float positions
- Redundant-off function as standard
- UL 508 listing in US and Canada

## Standard Models

MVP-S1DM, MVP-S2DM

## Product Code Diagram

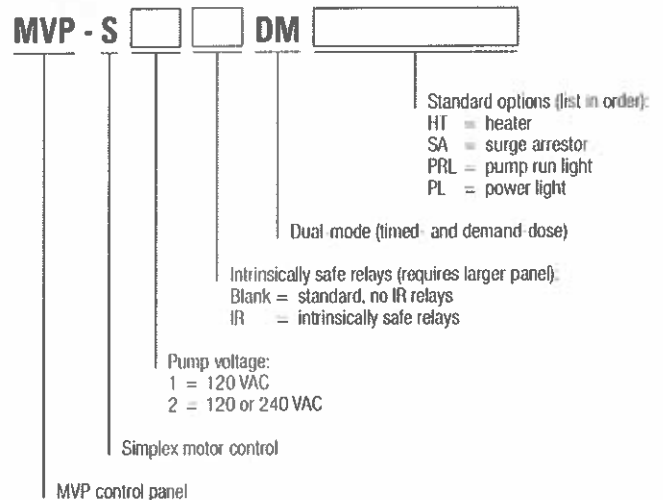

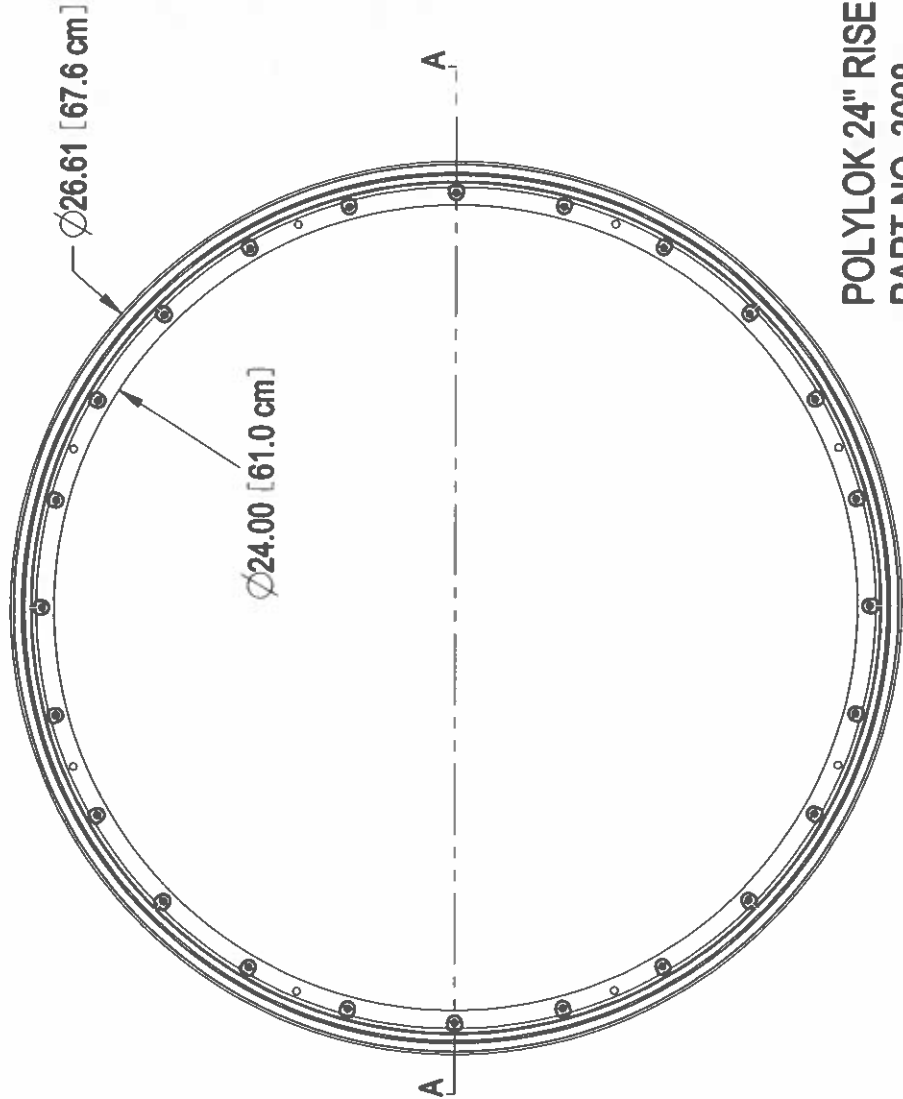
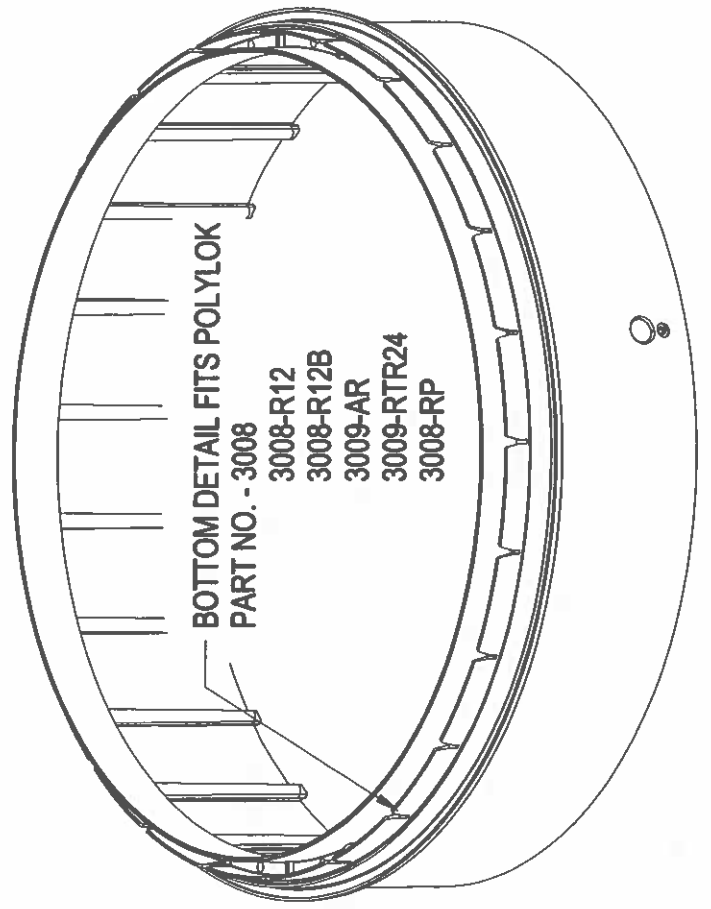
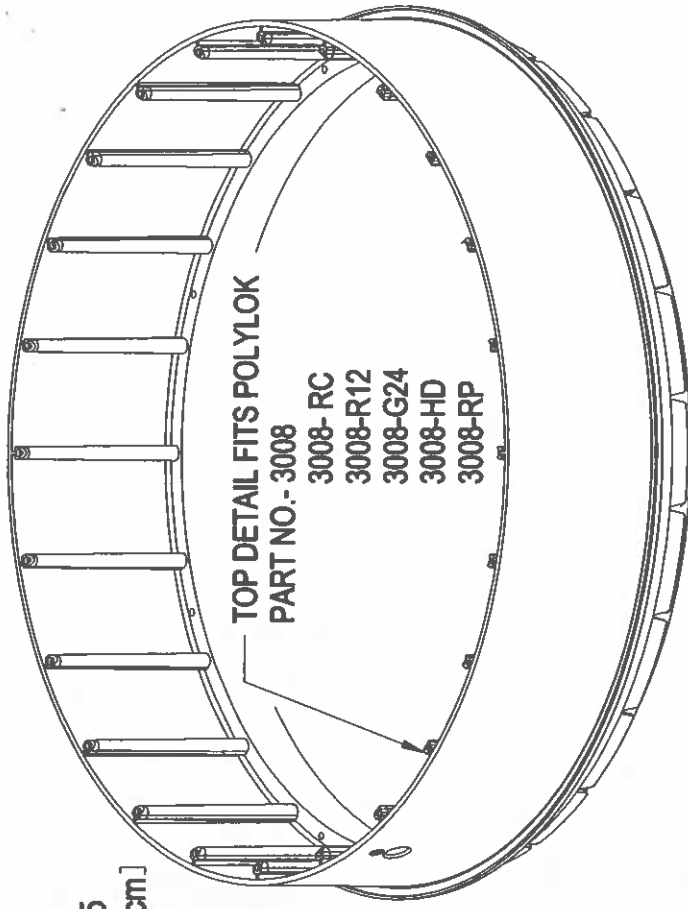
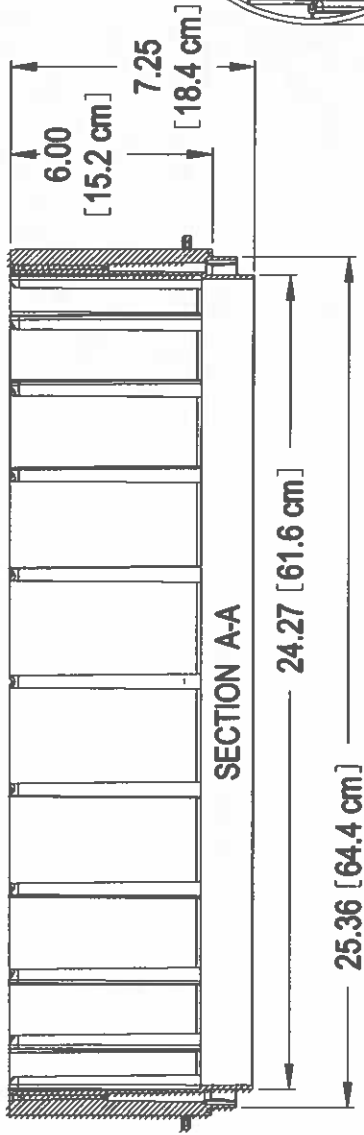

POLYLOK 24" RISER  
PART NO. 3008  
MATERIAL - HDPE  
COLOR - GREEN

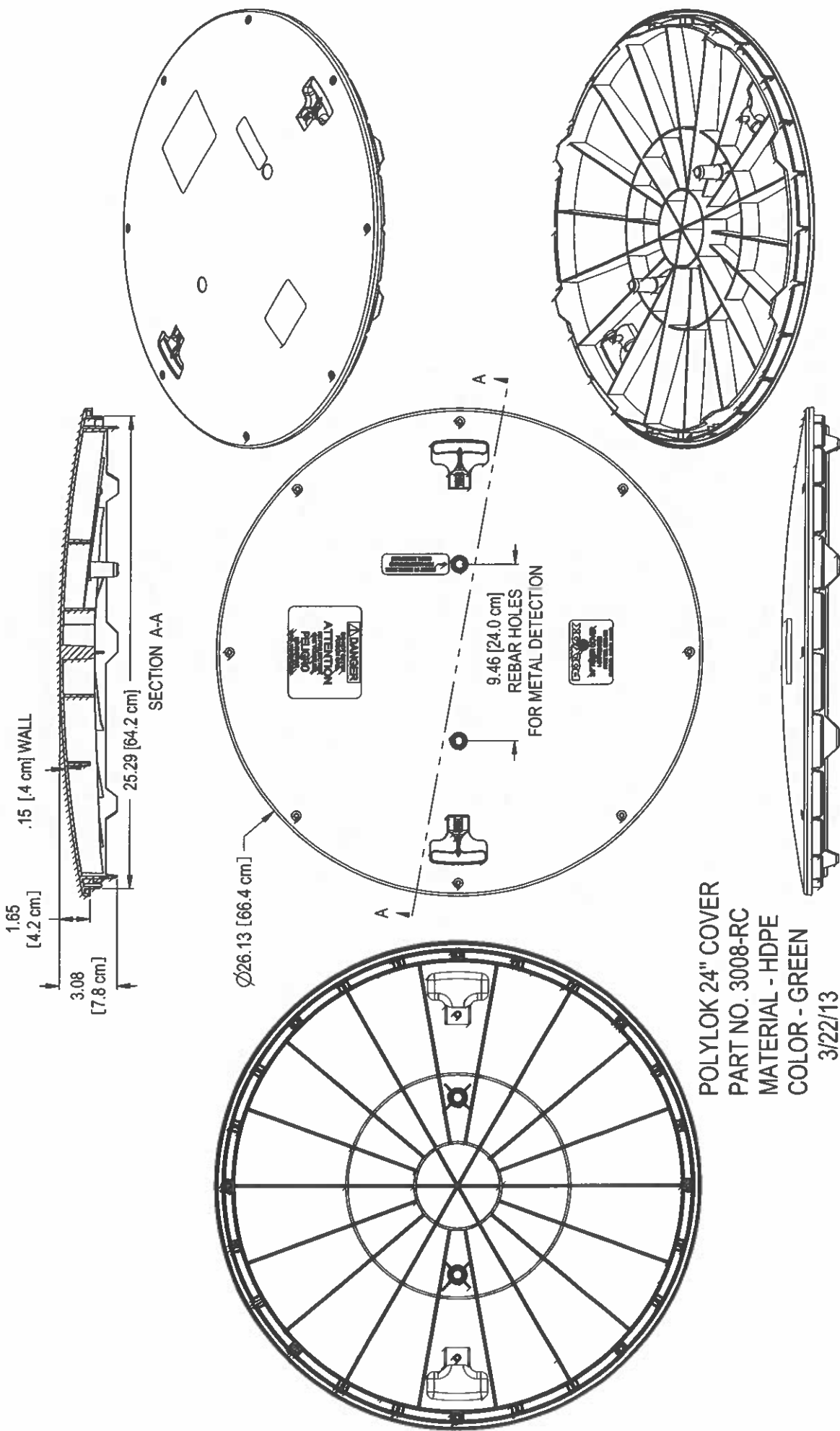

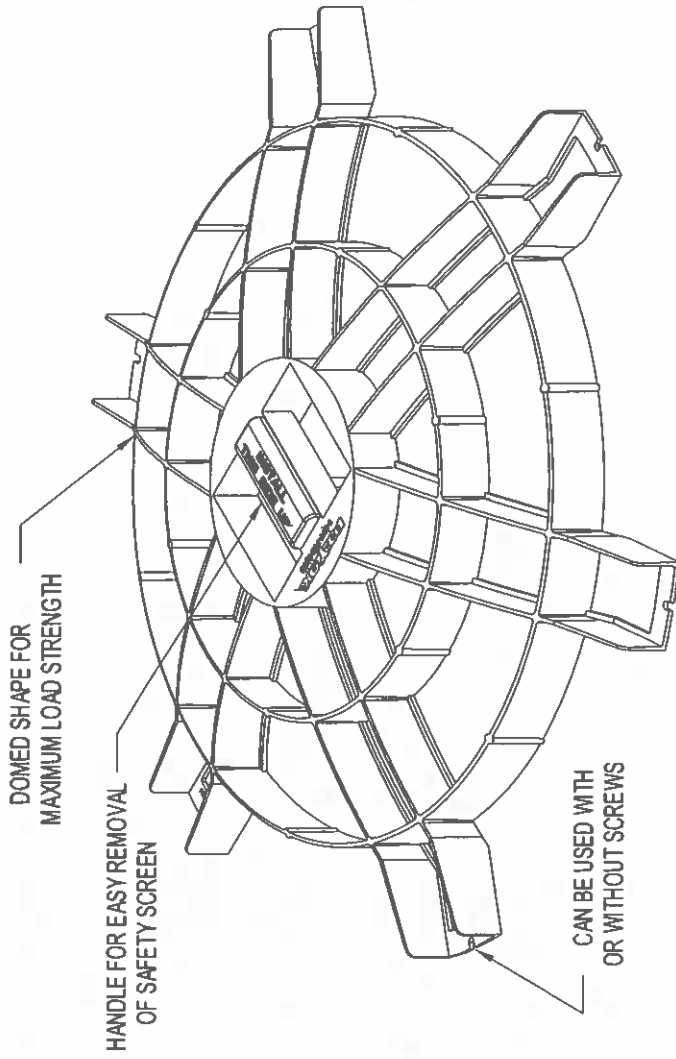

POLYLOK 24" SAFETY SCREEN  
PART NO. - 3008-SS  
MATERIAL - ABS

