



Search Street Listing Sales Search Feedback Back Home

45 ARTWILL AVE

Sales Print Field Card Map It

Table with property details: Location (45 ARTWILL AVE), Mblu (0229/ 0001/ 0002/ /), Acct# (54751), Owner (DOUGLASS NICOLA D LV TR), PBN, Assessment (\$1,500,600), Appraisal (\$1,500,600), PID (54751), Building Count (1)

Current Value

Table with Appraisal and Assessment data for 2025, showing Valuation Year, Improvements, Land, and Total values.

Owner of Record

Table with Owner details: Owner (DOUGLASS NICOLA D LV TR), Co-Owner (DOUGLASS WILLIAM K LV TR), Address (45 ARTWILL AVE, PORTSMOUTH, NH 03801), Sale Price (\$0), Certificate, Book & Page (6668/966), Sale Date (12/01/2025), Instrument

Ownership History

Table with Ownership History: Owner, Sale Price, Certificate, Book & Page, Instrument, Sale Date

Building Information

Building 1 : Section 1

Year Built: 2023, Living Area: 3,454, Replacement Cost: \$1,108,166, Building Percent Good: 99, Replacement Cost, Less Depreciation: \$1,097,100

Building Photo



Building Layout

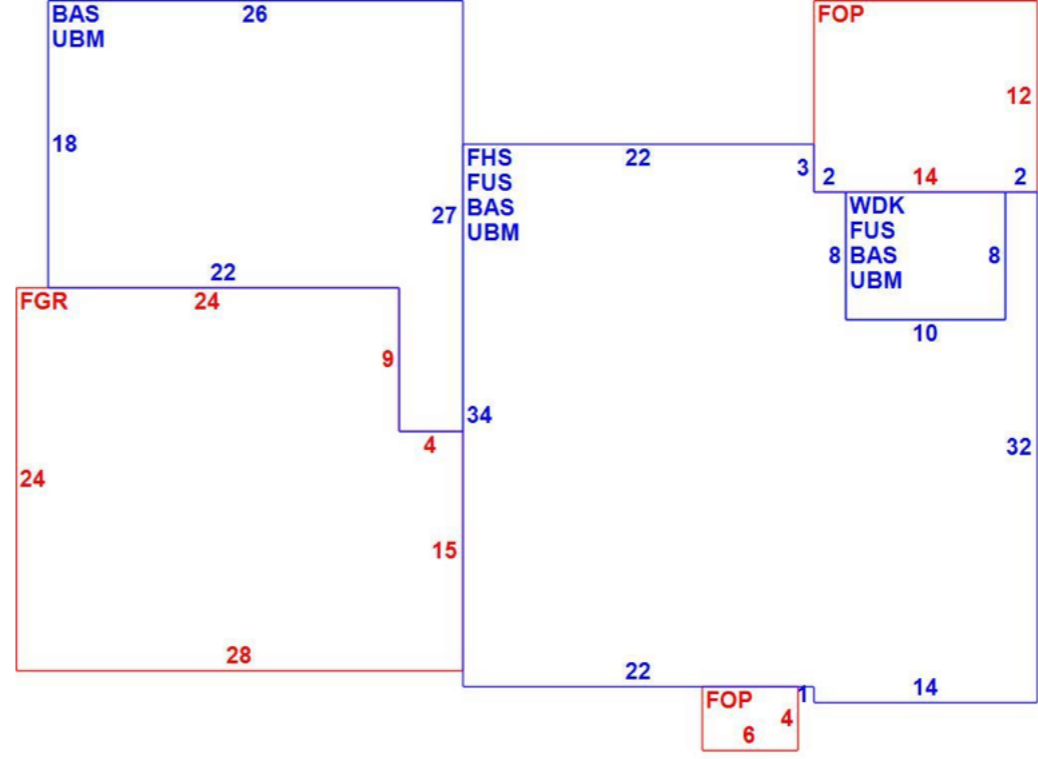

Table with Building Sub-Areas (sq ft) and Legend: Code, Description, Gross Area, Living Area

Extra Features

Table with Extra Features: Code, Description, Size, Value, Bldg #

Land

Land Use

Use Code 1010, Description SINGLE FAM MDL-01, Zone SRB, Neighborhood 125, Alt Land Appr No, Category

Land Line Valuation

Size (Acres) 0.70, Frontage, Depth, Assessed Value \$354,300, Appraised Value \$354,300

Outbuildings

Table with Outbuildings: Code, Description, Sub Code, Sub Description, Size, Value, Bldg #

Valuation History

Table with Appraisal history for 2025, 2024, and 2023, showing Valuation Year, Improvements, Land, and Total values.

Table with Assessment history for 2025, 2024, and 2023, showing Valuation Year, Improvements, Land, and Total values.