

9 TARLETON LN

Location 9 TARLETON LN

Mblu 006/ 028/ 028/ /

Acct# 7996

Owner GHANNAM JEFFREY A

Assessment \$485,900

PID 101457

Building Count 1

Current Value

Assessment			
Valuation Year	Improvements	Land	Total
2021	\$485,900	\$0	\$485,900

Owner of Record

Owner GHANNAM JEFFREY A
Co-Owner ZNAMIEROWSKI JOYCE H
Address 9 TARLETON LN
 AMHERST, NH 03031

Sale Price \$483,800
Certificate
Book & Page 7655/0467
Sale Date 04/03/2006
Instrument 00

Ownership History

Ownership History					
Owner	Sale Price	Certificate	Book & Page	Instrument	Sale Date
GHANNAM JEFFREY A	\$483,800		7655/0467	00	04/03/2006
STABILE HOMES AT AMHERST LLC	\$3,500,000		7397/0529	1W	01/24/2005
	\$0		/0		

Building Information

Building 1 : Section 1

Year Built: 2006
Living Area: 2,238
Replacement Cost: \$541,931
Building Percent Good: 89
Replacement Cost
Less Depreciation: \$482,300

Building Attributes	
Field	Description

Style:	Condominium
Model	Res Condo
Stories:	1 Story
Grade	Good
Occupancy	1
Interior Wall 1:	Drywall/Sheet
Interior Wall 2:	
Interior Floor 1	Carpet
Interior Floor 2	Hardwood
Heat Fuel:	Gas
Heat Type:	Forced Air-Duc
AC Type:	Central
Ttl Bedrms:	2 Bedrooms
Ttl Bathrms:	2 Full
Ttl Half Bths:	1
Xtra Fixtres	1
Total Rooms:	7
Bath Style:	Average
Kitchen Style:	Typical
Kitchen Type	00
Kitchen Func	00
Primary Bldg Use	
Htwtr Type	00
Atypical	
Park Type	N
Park Own	N
Park Tandem	N
Fireplaces	
Num Part Bedrm	
Base Flr Pm	
Num Park	00
Pct Low Ceiling	
Unit Lochn	
Grade	Good
Stories:	1
Residential Units:	17
Exterior Wall 1:	AL/Vinyl
Exterior Wall 2:	
Roof Structure	Gable/Hip
Roof Cover	Asph/F Gls/Cmp
Cmrc Units:	0

Building Photo



(https://images.vgsi.com/photos/AmherstNHPhotos/\0013\DSC04321_13

Building Layout

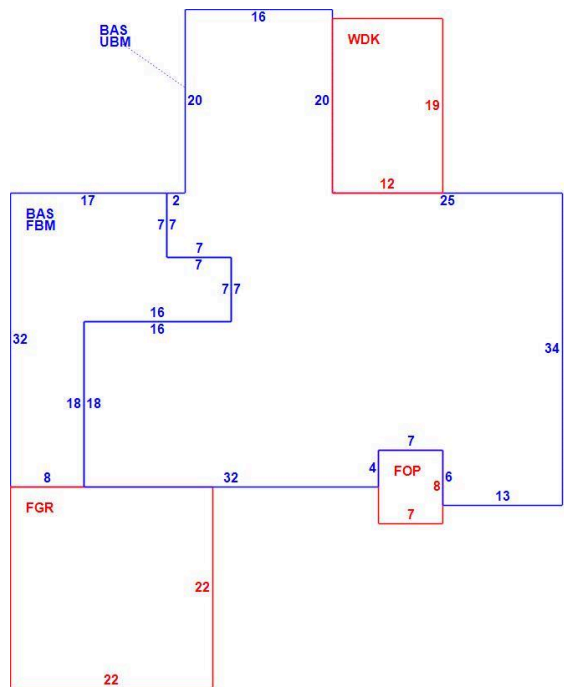

(ParcelSketch.ashx?pid=101457&bid=5541)

Building Sub-Areas (sq ft)			Legend	
Code	Description	Gross Area	Living Area	
BAS	First Floor	2,238	2,238	
FBM	Basement, Finished	431	0	
FGR	Garage, Framed	484	0	
FOP	Porch, Open, Finished	56	0	
UBM	Basement, Unfinished	1,807	0	
WDK	Deck, Wood	228	0	
		5,244	2,238	

Res/Com Units:	0
Section #:	
Parking Spaces	
Section Style:	
Foundation	
Security:	
Cmplx Cnd	
Xtra Field 1:	
Remodel Ext:	
Super	
Grade	

Extra Features

Extra Features				<u>Legend</u>
Code	Description	Size	Value	Bldg #
FPL	FIREPLACE	1.00 UNITS	\$2,700	1
GEN	GENERATOR SML	1.00 UNITS	\$900	1

Land

Land Use

Use Code 1020
Description CONDO MDL-05
Zone RR
Neighborhood
Alt Land Appr No
Category

Land Line Valuation

Size (Acres) 0
Frontage
Depth
Assessed Value \$0

Outbuildings

Outbuildings						<u>Legend</u>
Code	Description	Sub Code	Sub Description	Size	Value	Bldg #
PAV3	DRV RESI PVD SML			1.00 UNITS	\$0	1

Valuation History

Assessment			
Valuation Year	Improvements	Land	Total
2025	\$485,900	\$0	\$485,900
2024	\$485,900	\$0	\$485,900
2023	\$485,900	\$0	\$485,900

