

21 WILLOWBROOK AVE

Location 21 WILLOWBROOK AVE

Mblu 0/R 11/ 1/ /

Acct# 881

Owner ROMPS MICHAEL F

Assessment \$1,087,300

Appraisal \$1,087,300

PID 398

Building Count 1

Current Value

Appraisal			
Valuation Year	Improvements	Land	Total
2024	\$694,900	\$392,400	\$1,087,300

Assessment			
Valuation Year	Improvements	Land	Total
2024	\$694,900	\$392,400	\$1,087,300

Owner of Record

Owner ROMPS MICHAEL F
Co-Owner ROMPS JACLYN
Address 21 WILLOWBROOK AVE
GREENLAND , NH 03804

Sale Price \$634,000
Certificate
Book & Page 6097/416
Sale Date 03/30/2020
Instrument 00

Ownership History

Ownership History					
Owner	Sale Price	Certificate	Book & Page	Instrument	Sale Date
ROMPS MICHAEL F	\$634,000		6097/416	00	03/30/2020
ONE HOME BUILDERS II LLC	\$0		6069/925	1N	12/23/2019
ONE HOME BUILDERS II LLC	\$920,000		6027/1262		08/19/2019
SWEET MEADOW REALTY TRUST	\$106,000		3117/1515	1N	09/07/1995
MUELLER THEODORE L	\$114,824		02522/0658	00	11/28/1984

Building Information

Building 1 : Section 1

Year Built: 1997

Living Area: 3,194
Replacement Cost: \$765,067
Building Percent Good: 89
Replacement Cost Less Depreciation: \$680,900

Building Attributes

Field	Description
Style:	Cape Cod
Model	Residential
Grade:	Good +10
Stories:	1 3/4 Stories
Occupancy	2
Exterior Wall 1	Clapboard
Exterior Wall 2	
Roof Structure:	Gable/Hip
Roof Cover	Asph/F Gls/Cmp
Interior Wall 1	Drywall/Sheet
Interior Wall 2	
Interior Flr 1	Hardwood
Interior Flr 2	
Heat Fuel	Oil
Heat Type:	Hot Water
AC Type:	None
Total Bedrooms:	4 Bedrooms
Total Bthrms:	3
Total Half Baths:	1
Total Xtra Fixtrs:	
Total Rooms:	9 Rooms
Bath Style:	Average
Kitchen Style:	Modern
Num Kitchens	01
Cndtn	
Num Park	
Fireplaces	
Fndtn Cndtn	
Basement	

Building Photo



(https://images.vgsi.com/photos/GreenlandNHPhotos/\00\00\24\87.jpg)

Building Layout

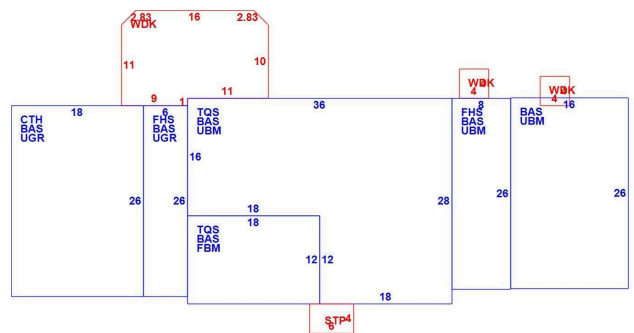

(ParcelSketch.aspx?pid=398&bid=422)

Building Sub-Areas (sq ft)			Legend
Code	Description	Gross Area	Living Area
BAS	First Floor	2,256	2,256
TQS	Three Quarter Story	1,008	756
FHS	Half Story, Finished	364	182
CTH	CATHEDERAL	468	0
FBM	Basement, Finished	216	0
STP	Stoop	24	0
UBM	Basement, Unfinished	1,416	0
UGR	Garage, Basement	624	0
WDK	Deck, Wood	277	0
		6,653	3,194

Extra Features

Extra Features				Legend
Code	Description	Size	Value	Bldg #
FPL2	1.5 STORY CHIM	1.00 UNITS	\$5,200	1

Land

Land Use

Use Code 1015
Description SFR/ACC
Zone RES
Neighborhood
Alt Land Appr Category No

Land Line Valuation

Size (Acres) 3.43
Frontage 0
Depth 0
Assessed Value \$392,400
Appraised Value \$392,400

Outbuildings

Outbuildings						<u>Legend</u>
Code	Description	Sub Code	Sub Description	Size	Value	Bldg #
PAT1	PATIO-AVG			270.00 S.F.	\$1,700	1
SHD1	SHED FRAME			80.00 S.F.	\$1,100	1
DRP3	DRV RES LARGE			1.00 UNITS	\$6,000	1

Valuation History

Appraisal			
Valuation Year	Improvements	Land	Total
2024	\$694,900	\$392,400	\$1,087,300
2023	\$694,900	\$392,400	\$1,087,300
2022	\$351,000	\$224,600	\$575,600

Assessment			
Valuation Year	Improvements	Land	Total
2024	\$694,900	\$392,400	\$1,087,300
2023	\$694,900	\$392,400	\$1,087,300
2022	\$351,000	\$224,600	\$575,600