

Jimmy H. Cowan, Jr., CFA

# Marion County Property Appraiser



501 SE 25th Avenue, Ocala, FL 34471 Telephone: (352) 368-8300 Fax: (352) 368-8336

## 2026 Property Record Card

3506-009-012

[GOOGLE Street View](#)

Prime Key: 852767

[MAP IT+](#)

Current as of 6/6/2026

### [Property Information](#)

DESANTIS RICHARD JOHN  
DESANTIS TERESA ANN  
10800 SW 55TH AVE  
OCALA FL 34476-7075

### [Taxes / Assessments:](#)

Map ID: 150

[Millage:](#) 9002 - UNINCORPORATED

[M.S.T.U.](#)

[PC:](#) 01

Acres: .51

Situs: 10800 SW 55TH AVE OCALA

### [2025 Certified Value](#)

Land Just Value	\$52,320		
Buildings	\$224,599		
Miscellaneous	\$6,979		
Total Just Value	\$283,898	Impact	
Total Assessed Value	\$145,396	<a href="#">Ex Codes:</a>	(\$138,502)
Exemptions	(\$50,722)		
Total Taxable	\$94,674		
School Taxable	\$120,396		

### [History of Assessed Values](#)

Year	Land Just	Building	Misc Value	Mkt/Just	Assessed Val	Exemptions	Taxable Val
2025	\$52,320	\$224,599	\$6,979	\$283,898	\$145,396	\$50,722	\$94,674
2024	\$42,510	\$235,348	\$6,616	\$284,474	\$141,298	\$50,000	\$91,298
2023	\$38,586	\$231,560	\$7,177	\$277,323	\$137,183	\$50,000	\$87,183

### [Property Transfer History](#)

Book/Page	Date	Instrument	Code	Q/U	V/I	Price
<a href="#">8695/0683</a>	08/2025	07 WARRANTY	4 V-APPRAISERS OPINION	Q	I	\$360,000
<a href="#">7800/1173</a>	05/2022	07 WARRANTY	0	U	I	\$100
<a href="#">7643/0867</a>	09/2021	61 FJDMNT	0	U	I	\$100
<a href="#">7018/1681</a>	07/2019	07 WARRANTY	7 PORTIONUND INT	U	I	\$100
<a href="#">6119/1668</a>	10/2014	06 SPECIAL WARRANTY	2 V-SALES VERIFICATION	U	I	\$140,000
<a href="#">6119/1667</a>	05/2014	57 TRANSFER FROM BANK	0	U	I	\$100
<a href="#">6035/0110</a>	05/2014	56 TRANSFER TO BANK	0	U	I	\$200
<a href="#">DETH/REGS</a>	02/2011	71 DTH CER	0	U	I	\$100
<a href="#">3154/1241</a>	04/2002	07 WARRANTY	2 V-SALES VERIFICATION	Q	I	\$137,600
<a href="#">2817/1076</a>	07/2000	07 WARRANTY	2 V-SALES VERIFICATION	Q	I	
<a href="#">1518/0130</a>	07/1988	07 WARRANTY	9 UNVERIFIED	U	I	
<a href="#">1517/1500</a>	07/1988	07 WARRANTY	9 UNVERIFIED	U	I	
<a href="#">1513/1556</a>	06/1988	05 QUIT CLAIM	0	U	V	\$100

[Property Description](#)

SEC 28 TWP 16 RGE 21  
PLAT BOOK N PAGE 086  
KINGSLAND COUNTRY ESTATES WHISPERING PINES  
BLK 9 LOT 12

[Land Data - Warning: Verify Zoning](#)

Use	CUse	Front	Depth	Zoning	Units	Type	Rate	Loc	Shp	Phy	Class Value	Just Value
0100		98.0	227.0	R1	98.00	FF						
Neighborhood 8045												
Mkt: 9 70												

[Traverse](#)

**Building 1 of 1**

RES01=U4R5U8R22U42L24D19L8D10L28D28R4D3R8U3R3U3R18.  
FOP02=D12R5U16L5D4.D12R5  
FGR03=R22U24L22D24.U51L2  
FSP04=D4L8D10L28U8R16U6R20.  
EPA05=U21L36D27R16U6R20.

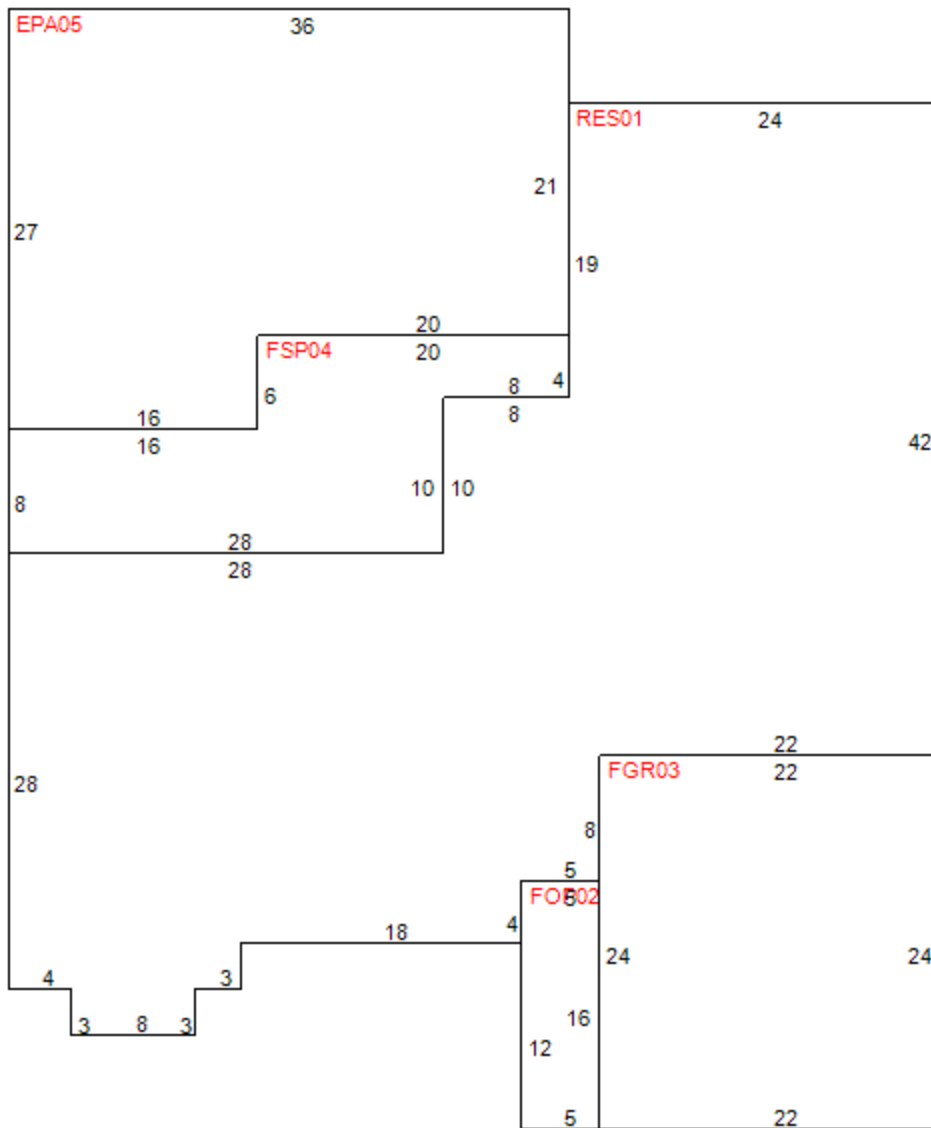

Building Characteristics

**Improvement** 1F - SFR- 01 FAMILY RESID  
**Effective Age** 5 - 20-24 YRS  
**Condition** 4  
**Quality Grade** 600 - AVERAGE  
**Inspected on** 3/24/2025 by 211

**Year Built** 1988  
**Physical Deterioration** 0%  
**Obsolescence: Functional** 0%  
**Obsolescence: Locational** 0%  
**Architecture** 0 - STANDARD SFR  
**Base Perimeter** 240

TypeID	Exterior Walls	Stories	Year Built	Finished Attic	Bsmt Area	Bsmt Finish	Ground Floor Area	Total Flr Area
RES 0132	- CONC BLK-STUCO	1.00	1988	N	0 %	0 %	2,061	2,061
FOP 0201	- NO EXTERIOR	1.00	1988	N	0 %	0 %	80	80
FGR 0332	- CONC BLK-STUCO	1.00	1988	N	0 %	0 %	528	528
FSP 0401	- NO EXTERIOR	1.00	1988	N	0 %	0 %	328	328
EPA 0501	- NO EXTERIOR	1.00	1988	N	0 %	0 %	852	852

**Section: 1**

<b>Roof Style:</b> 10 GABLE	<b>Floor Finish:</b> 24 CARPET	<b>Bedrooms:</b> 3	<b>Blt-In Kitchen:</b> Y
<b>Roof Cover:</b> 08 FBRGLASS SHNGL	<b>Wall Finish:</b> 16 DRYWALL-PAINT	<b>4 Fixture Baths:</b> 1	<b>Dishwasher:</b> Y
<b>Heat Meth 1:</b> 20 HEAT PUMP	<b>Heat Fuel 1:</b> 10 ELECTRIC	<b>3 Fixture Baths:</b> 1	<b>Garbage Disposal:</b> N
<b>Heat Meth 2:</b> 00	<b>Heat Fuel 2:</b> 00	<b>2 Fixture Baths:</b> 0	<b>Garbage Compactor:</b> N
	<b>Fireplaces:</b> 0	<b>Extra Fixtures:</b> 2	

**Foundation:** 7 BLK PERIMETER  
**A/C:** Y

**Intercom:** N  
**Vacuum:** N

Miscellaneous Improvements

<b>Type</b>	<b>Nbr</b>	<b>Units</b>	<b>Type</b>	<b>Life</b>	<b>Year In</b>	<b>Grade</b>	<b>Length</b>	<b>Width</b>
190 SEPTIC 1-5 BTH	1.00		UT	99	1988	2	0.0	0.0
256 WELL 1-5 BTH	1.00		UT	99	1988	2	0.0	0.0
159 PAV CONCRETE	1,326.00		SF	20	1988	3	0.0	0.0
099 DECK	852.00		SF	50	1988	3	0.0	0.0
226 RES SWIM POOL	288.00		SF	20	1988	5	0.0	0.0
112 FENCE WIRE/BD	223.00		LF	10	1998	5	0.0	0.0
116 FENCE VINYL	40.00		LF	99	2022	4	0.0	0.0

Appraiser Notes

Planning and Building

\*\* Permit Search \*\*

<b>Permit Number</b>	<b>Date Issued</b>	<b>Date Completed</b>	<b>Description</b>
2024052875	5/1/2024	9/5/2024	REPLACE 1 WINDOW & 2 SGD;S SIZE FOR SIZE. FL.16439.1 & FL.4
2023092497	9/25/2023	10/11/2023	SHINGLE TEAR OFF SHINGEL REROOF SFR FL16305.1 FL16226.1
MA17365	10/1/1988	11/1/1988	POOL ENCL.
MA16544	9/1/1988	10/1/1988	POOL
MA14967	7/1/1988	10/1/1988	RES