

HOME INSPECTION REPORT

**10139 Cabot Dr
St. Louis, MO 63137**

Inspection Date:
6/29/2026 6:00 PM

Prepared For:
Malinda Terreri

Prepared By:
Derek Ehlert Enterprises, LLC
8706 Florence Ave.
St. Louis, MO 63144
636-277-0044
derekehlert@a-pro.net

Report Number:
062926DE

Inspector:
Derek Ehlert CHI/PHI
ASHI # 264657



TABLE OF CONTENTS

REPORT OVERVIEW	3
STRUCTURAL / FOUNDATION	6
STRUCTURAL / FOUNDATION PHOTO SUMMARY	7
ROOFING	8
ROOFING PHOTO SUMMARY	9
EXTERIOR	10
EXTERIOR PHOTO SUMMARY	11
ELECTRICAL SYSTEM	12
ELECTRICAL SYSTEM PHOTO SUMMARY	14
HEATING SYSTEM	16
COOLING SYSTEM	17
COOLING SYSTEM PHOTO SUMMARY	18
INSULATION / VENTILATION	19
PLUMBING SYSTEM	20
PLUMBING SYSTEM PHOTO SUMMARY	22
INTERIOR	23
INTERIOR PHOTO SUMMARY	25
APPLIANCES	27
APPLIANCES PHOTO SUMMARY	28
MAINTENANCE ADVICE	30
THE A-PRO HOME MAINTENANCE CHECKLIST	32
HOME MAINTENANCE GUIDE	44
IT TAKES A-PRO TO KNOW...	58
DON'T BUY A HOME WITHOUT US!	58

REPORT OVERVIEW

THE HOUSE IN PERSPECTIVE

This is an average quality 75 year old home that has been lacking maintenance. Apart from the short term need to deal with this lacking maintenance, the improvements that are recommended in this report are not considered unusual for a home of this age and location. Please remember that there is no such thing as a perfect home.

KEYS USED IN THIS REPORT

For your convenience, the following keys have been used in this report.

- **Major Concern:** Denotes an improvement recommendation that is uncommon for a building of this age or location and /or that needs immediate repair or replacement.
- **Safety Issue:** Denotes an observation or recommendation that is considered an immediate safety concern.
- **Improve:** Denotes a typical improvement recommendation that is common for a building of this age and location that should be anticipated or budgeted for over the short term.
- **Monitor:** Denotes an area where further investigation by a specialized licensed contractor and/or monitoring is needed. Repairs may be necessary or desired. During the inspection, there was insufficient information or the observation was beyond the scope of the inspection. Improvements cannot be determined until further investigation or observations are made.

Note: Observations listed under “Discretionary Improvements” are not essential repairs, but represent logical long-term improvements.

For the purpose of this report, it is assumed that the house faces north.

WEATHER CONDITIONS

Dry weather conditions prevailed at the time of the inspection. The estimated outside temperature was 92 degrees F.

RECENT WEATHER CONDITIONS

Wet weather conditions have been experienced in the days leading up to the inspection.

IMPROVEMENT RECOMMENDATION HIGHLIGHTS

The following is a synopsis of the potentially significant improvements that should be budgeted for over the short term. Other significant improvements, outside the scope of this inspection, may also be necessary. Please refer to the body of this report for further details on these and other recommendations.

SAFETY ISSUE

Supply Plumbing

- **Safety Issue:** The hot/cold water supplies are reversed at the sink in the bathroom. This condition represents a potential scald hazard. See **Photo 22**

Porch

- **Safety Issue:** As there is a danger of falling, a railing should be provided for the porch at the front of the house. See **Photo 9**

IMPROVE

Sloped Roofing

- **Improve:** Minor repairs to the roofing are recommended. Damaged or missing roofing material should be repaired. All roof penetrations should be examined and sealed as necessary. **See Photos 5-8**

Outlets

- **Improve:** An outlet is inoperative in the rear bedroom. This outlet and circuit should be investigated. **See Photo 12**
- **Improve:** A ground fault circuit interrupter (GFCI) outlet in the garage is inoperative. This circuit should be investigated. **See Photos 13-14**

Refrigerator

- **Improve:** There is evidence of leakage from the refrigerator. Further review by a service technician is recommended. **See Photo 35**
- **Improve:** The refrigerator door gasket should be improved. **See Photo 36**

MONITOR ITEMS

Foundation

- **Monitor:** Minor vertical cracking was observed in the foundation at the rear of the house. This type of cracking is usually the result of shrinkage of the concrete as it cures. Shrinkage cracks are very common and should not be cause for alarm. **See Photo 3**

Main Panel

- **Monitor:** The main distribution panel shows evidence of rusting, suggesting the presence of moisture. This area should be monitored. If rusting continues, or if moisture is evident in the vicinity of the panel, an electrician should be consulted. **See Photo 15**

THE SCOPE OF THE INSPECTION

All components designated for inspection in the ASHI Inspector Standards are inspected, except as may be noted in the "Limitations of Inspection" sections within this report. The ASHI Inspector Standards can be found at the end of this report and are made part of the inspection.

This inspection is visual only. A representative sample of building components is viewed in areas that are accessible at the time of the inspection only. No destructive testing or dismantling of building components is performed.

Each mechanical system which conveys as part of the property and specifically listed as having been tested was observed to be in normal working condition at the time of inspection, unless one or more deficiencies for the listed system is reported. Latent defects may still exist, and evaluation of any system is limited by the conditions during the inspection and the scope defined by the ASHI Home Inspection Standards of Practice.

Please understand the importance of limitations in a home inspection. This report does not reflect the results of an exhaustive technical evaluation, but rather a visual inspection. The distinction between the two is important. A technical evaluation requires exhaustive testing and analysis of a house's parts, taking more time and costing significantly more money. Our inspection does not consider components in the home that are not visible. Also understand that, even with an exhaustive inspection, there still may be defects in the home that are not revealed during the inspection. A visual inspection provides you with a solid, overall picture of the home, its problems, positive attributes, and areas where we recommended immediate attention. But with anything as complex as a home (a home has roughly 500 separate components), unexpected repairs are the norm, not the exception.

It is the goal of the inspection to put a homebuyer in a better position to make a buying decision. Not all improvements will be identified during this inspection. Unexpected repairs should still be anticipated. The inspection should not be considered a guarantee or warranty of any kind.

Please refer to the pre-inspection contract for a full explanation of the scope of the inspection.

It is strongly recommended that a Homeowner's Warranty or service contract be purchased to cover the operation of Appliances, the Electrical System, the Air Conditioning System (s), Heating System(s), and the Plumbing System.

Verification of compliance with current or past Building Code and/or Zoning Regulations or requirements is outside the scope of this inspection.

Addendum Specific to This Inspection

As the intention of this inspection was to identify major defects of the house as it is prepared for sale the scope and time allotted was limited (~ 1 hr.) For this inspection, the scope was limited to a general overview of the property and identification of any visible major deficiencies that may exist. Due to the limited nature of this inspection, non-major items were not a focus. Please refer to the limitations listed in each section for additional information.

Please refer to the ASHI Inspector Standards and the inspection authorization and agreement for a full explanation of the scope of the inspection.

STRUCTURAL / FOUNDATION

DESCRIPTION OF STRUCTURAL / FOUNDATION COMPONENTS

Foundation:	●Poured Concrete ●Basement Configuration
Columns:	●Steel
Floor Structure:	●Wood Joist
Wall Structure:	●Wood Frame
Roof Structure:	●Rafters
Attic Method of Inspection:	●Viewed From Hatch

STRUCTURAL / FOUNDATION COMPONENT OBSERVATIONS

Positive Attributes

The construction of the home is considered to be good quality. The materials and workmanship, where visible, are above average. No major defects were observed in the accessible structural components of the house. The building exhibits no evidence of substantial structural movement.

RECOMMENDATIONS / OBSERVATIONS

Foundation

- **Improve:** Surface deterioration was observed at the west side of the house. This condition is common in many older homes and does not usually represent a serious structural concern. In an effort to prevent long-term deterioration, it would be wise to consider parging deteriorated areas. Lot drainage improvements, as outlined in the "Exterior" section of this report are also recommended **See Photo 1**
- **Monitor:** Prior repairs were noted to the foundation. It may be wise to consult the seller as to when and what repairs became necessary. **See Photo 2**
- **Monitor:** Minor vertical cracking was observed in the foundation at the rear of the house. This type of cracking is usually the result of shrinkage of the concrete as it cures. Shrinkage cracks are very common and should not be cause for alarm. **See Photo 3**

LIMITATIONS OF STRUCTURAL / FOUNDATION COMPONENT INSPECTION

As prescribed in the inspection authorization and agreement, this is a visual inspection only. Assessing the structural integrity of a building is beyond the scope of a standard home inspection. A certified Licensed Professional Engineer (P.E.) is recommended where there are structural concerns about the building. Inspection of structural components was limited by (but not restricted to) the following conditions:

- Structural components concealed behind finished surfaces could not be inspected.
- Only a representative sampling of visible structural components was inspected.
- Furniture and/or storage restricted access to some structural components.
- Insulation obstructed the view of some structural components in the attic.

Please refer to the ASHI Inspector Standards for a full explanation of the scope of the inspection.

STRUCTURAL / FOUNDATION PHOTO SUMMARY



Photo 1: Surface Deterioration.



Photo 2: Prior Foundation Repairs.



Photo 3: Cracks Minor - Shrinkage.

ROOFING

DESCRIPTION OF ROOFING COMPONENTS

Roof Covering:	●Composite Shingle
Chimneys:	●Metal
Gutters and Downspouts:	●Aluminum
Method of Inspection:	●Walked on Roof

ROOFING COMPONENT OBSERVATIONS

Positive Attributes

No prior roof leaks were observed on the underside of the roof sheathing. The steep pitch of the roof should result in a longer than normal life expectancy for roof coverings.

RECOMMENDATIONS / OBSERVATIONS

Sloped Roofing

- **Improve:** The missing cap on the metal roof vent should be replaced **See Photo 4**
- **Improve:** Minor repairs to the roofing are recommended. Damaged or missing roofing material should be repaired. All roof penetrations should be examined and sealed as necessary. **See Photos 5-8**

LIMITATIONS OF ROOFING COMPONENT INSPECTION

As prescribed in the inspection authorization and agreement, this is a visual inspection only. Roofing life expectancies can vary depending on several factors. Any estimates of remaining life are approximations only. This assessment of the roof does not preclude the possibility of leakage. Leakage can develop at any time and may depend on rain intensity, wind direction, ice build-up, etc. The inspection of the roofing system was limited by (but not restricted to) the following conditions:

- The entire underside of the roof sheathing is not inspected for evidence of leakage.
- Evidence of prior leakage may be disguised by interior finishes.
- No comment can be offered on the condition of the membrane below the roof coverings.

Please refer to the ASHI Inspector Standards for a full explanation of the scope of the inspection.

ROOFING PHOTO SUMMARY



Photo 4: Roof Vent Cap Missing.



Photo 5: Minor Repairs Only.



Photo 6: Minor Repairs Only.



Photo 7: Minor Repairs Only.



Photo 8: Minor Repairs Only.

EXTERIOR

DESCRIPTION OF EXTERIOR COMPONENTS

Wall Cladding:	● Vinyl Siding
Soffit, Eaves and Fascia:	● Aluminum
Window/Door Frames and Trim:	● Vinyl ● Metal
Driveways:	● Concrete
Walkways and Patios:	● Concrete
Porches, Decks and Steps:	● Concrete ● Wood
Overhead Garage Door:	● Metal
Lot Grading:	● Level Grade
Fencing:	● Chain Link

EXTERIOR COMPONENT OBSERVATIONS

Positive Attributes

Generally speaking, the exterior of the home is in good condition. The exterior siding that has been installed on the house is relatively low maintenance. The driveway, patio, and walkways are in good condition. The wall cladding was observed to be in generally good condition. The entry doors appear to be in good condition and work properly.

RECOMMENDATIONS / OBSERVATIONS

Porch

- **Safety Issue:** As there is a danger of falling, a railing should be provided for the porch at the front of the house. **See Photo 9**

Garage

- **Monitor:** Minor physical damage and a missing roller was observed to the overhead garage door. It should be repaired as necessary. **See Photos 10-11**

LIMITATIONS OF EXTERIOR COMPONENT INSPECTION

As prescribed in the inspection authorization and agreement, this is a visual inspection only. The inspection of the exterior was limited by (but not restricted to) the following conditions:

- Only a representative sample of exterior components was inspected.
- The inspection does not include an assessment of geological conditions and/or site stability.
- There was an absence of historical evidence due to the installation of new siding.
- Interior finishes and/or insulation restricted the inspection of the garage.

Please refer to the ASHI Inspector Standards for a full explanation of the scope of the inspection.

EXTERIOR PHOTO SUMMARY



Photo 9: Porch Railing Needed.



Photo 10: Overhead Door Minor Damage.



Photo 11: Overhead Door Minor Damage.

ELECTRICAL SYSTEM

DESCRIPTION OF ELECTRICAL SYSTEM COMPONENTS

Size of Electric Service:	●120/240V Service: Size 200 Amp
Service Entrance Wires:	●Overhead
Main Disconnect:	●Located: Inside Main Panel
Service Ground:	●Aluminum
Main Distribution Panel:	●Panel Rating: 70 Amps ●Located: Basement
Distribution Wiring:	●Copper ●Aluminum
Receptacles:	●Grounded and Ungrounded
Ground Fault Circuit Interrupter:	●Bathroom ●Exterior ●Basement ●Kitchen

ELECTRICAL SYSTEM COMPONENT OBSERVATIONS

Positive Attributes

Generally speaking, the electrical system is in good order. The size of the electrical service is sufficient for typical single family needs. The distribution of electricity within the home is good. The majority of the older wiring within the home appears to have been updated, improving the safety of the system.

RECOMMENDATIONS / OBSERVATIONS

Outlets

- **Improve:** An outlet is inoperative in the rear bedroom. This outlet and circuit should be investigated. **See Photo 12**
- **Improve:** A ground fault circuit interrupter (GFCI) outlet in the garage is inoperative. This circuit should be investigated. **See Photos 13-14**

Main Panel

- **Monitor:** The main distribution panel shows evidence of rusting, suggesting the presence of moisture. This area should be monitored. If rusting continues, or if moisture is evident in the vicinity of the panel, an electrician should be consulted. **See Photo 15**
- **Monitor:** The electrical panel is older. As a general rule of thumb the life span of an electrical panel is approximately 20-30 years. Upgrading to a new panel may be a logical long term improvement. **See Photo 16**

Distribution Wiring

- **Monitor:** Aluminum wiring was observed in the panel. No connection points in fixtures or behind outlets was inspected. During the installation of any new hardware a licensed electrician should be consulted for improvements. It should be pointed out that the aluminum wiring itself is a perfectly acceptable electrical conductor. The connection points can experience overheating or become loose due to the properties of aluminum wiring. Upon fitting the wiring with the special connectors and outlets, the wiring is considered to be safe. No overheating was observed at the time of inspection in accessible areas. **See Photo 17**

Discretionary Electrical Improvements

- **Monitor:** Grounded outlets may be desirable in some areas where ungrounded outlets exist. This will depend on electrical needs. **See Photo 18**

LIMITATIONS OF ELECTRICAL SYSTEM COMPONENT INSPECTION

As prescribed in the inspection authorization and agreement, this is a visual inspection only. The inspection does not include low voltage systems, telephone wiring, intercoms, alarm systems, TV cable, timers or smoke detectors. The inspection of the electrical system was limited by (but not restricted to) the following conditions:

- Electrical components concealed behind finished surfaces could not be inspected.
- Only a representative sampling of outlets and light fixtures were tested.
- Furniture and/or storage restricted access to some electrical components.

Please refer to the ASHI Inspector Standards for a full explanation of the scope of the inspection.

ELECTRICAL SYSTEM PHOTO SUMMARY



Photo 12: Inoperative Outlet.



Photo 13: GFCI Inoperative.



Photo 14: GFCI Inoperative.

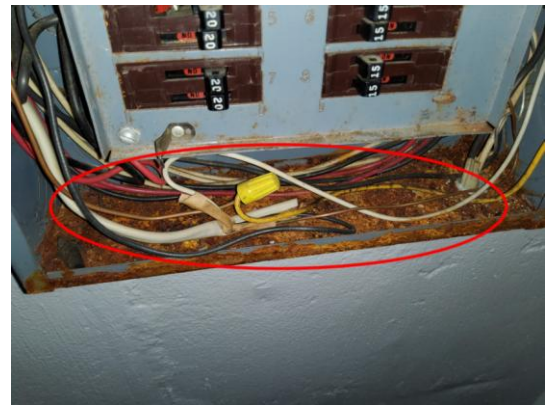

Photo 15: Rusted Panel.



Photo 16: Old Panel.



Photo 17: Aluminum Wiring.



Photo 18: Grounded Outlets.

HEATING SYSTEM

DESCRIPTION OF HEATING SYSTEM COMPONENTS

Primary Energy Source:	●Gas
Heating System Type:	●Forced Air
Heat Distribution Methods:	●Ductwork
Operating Controls:	●Wall Thermostat
Manufacturer:	●Rheem
System Description:	●Model: GF801U075AS36 ●Serial: GH5D302F511200373
	●Manufacturer Date: Dec 2012 ●Approximate Age (in years): 14
	●Air Filter Size: 16x25x1

HEATING SYSTEM COMPONENT OBSERVATIONS

Positive Attributes

The heating system is in generally good condition, when compared to systems of a similar age and configuration. The system responded properly to operating controls.

RECOMMENDATIONS / OBSERVATIONS

Furnace

- **Improve:** The heating system requires servicing. There is no evidence of recent servicing of the equipment. It would be advisable to inquire with the existing homeowner as to its last servicing. If it has been longer than twelve (12) months than it is wise to engage a qualified HVAC technician to service and check the system. See Photo 19



Photo #19

LIMITATIONS OF HEATING SYSTEM COMPONENT INSPECTION

As prescribed in the inspection authorization and agreement, this is a visual inspection only. The inspection of the heating system is general and not technically exhaustive. A detailed evaluation of the furnace heat exchanger is beyond the scope of this inspection. The inspection was limited by (but not restricted to) the following conditions:

- The adequacy of heat distribution is difficult to determine during a one-time visit to a home.
- Although the heating system was operated, there are significant testing limitations at this time of year.
- The heat exchanger was inaccessible and is not part of this inspection.

Please refer to the ASHI Inspector Standards for a full explanation of the scope of the inspection.

COOLING SYSTEM

DESCRIPTION OF COOLING SYSTEM COMPONENTS

Energy Source:	●Electricity
System Type:	●Air Cooled Central Air
Distribution Methods:	●Ductwork
Manufacturer:	●Goodman
System Description:	●Model: GSX130301LB ●Serial: 2005104593
	●Manufacturer Date: May 2020 ●Approximate Age (in years): 6

COOLING SYSTEM COMPONENT OBSERVATIONS

Positive Attributes

This is a relatively new system that should have many years of useful life remaining. Regular maintenance will, of course, be necessary. The system responded properly to operating controls. The system and its components are considered to be in good condition, when compared to systems of a similar age and configuration. Regular maintenance will, of course, be necessary.

RECOMMENDATIONS / OBSERVATIONS

Central Air Conditioning

- **Improve:** The outdoor unit of the air conditioning system requires cleaning. **See Photo 20**
- **Improve:** The insulation is missing from the refrigerant lines. It should be replaced. **See Photo 21**

LIMITATIONS OF COOLING SYSTEM COMPONENT INSPECTION

As prescribed in the inspection authorization and agreement, this is a visual inspection only. Air conditioning and heat pump systems, like most mechanical components, can fail at any time. The inspection of the cooling system was limited by (but not restricted to) the following conditions:

- The adequacy of distribution of cool air within the home is difficult to determine during a one-time inspection.

Please refer to the ASHI Inspector Standards for a full explanation of the scope of the inspection.

COOLING SYSTEM PHOTO SUMMARY



Photo 20: Outdoor Unit Dirty.

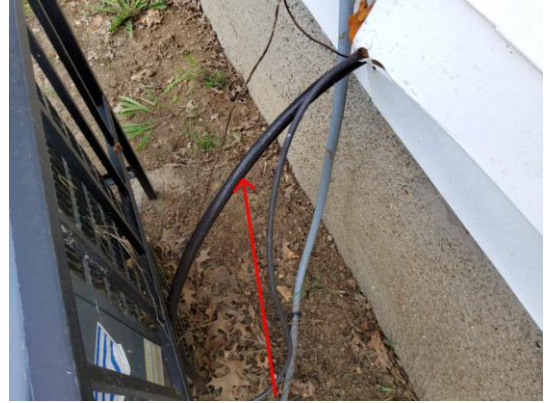

Photo 21: Insulation Missing on Refrigerant Lines .

INSULATION / VENTILATION

DESCRIPTION OF INSULATION / VENTILATION COMPONENTS

Attic Insulation:	● Loose Fill Fiberglass
Exterior Wall Insulation:	● Not Visible
Basement Wall Insulation:	● None
Air / Vapor Barrier:	● Not Visible
Roof Ventilation:	● Gable Vents
Exhaust Fans / Vent Locations:	● Bathroom ● Kitchen

INSULATION / VENTILATION COMPONENT OBSERVATIONS

Positive Attributes

The insulation and ventilation systems that were observed are typical for a home of this age and construction. The exhaust fans within the home functioned properly.

General Comments

Caulking and weather-stripping around doors, windows and other exterior wall openings will help to maintain weather tightness and reduce energy costs.

RECOMMENDATIONS / OBSERVATIONS

No improvements are necessary to this component of the home at this time.

LIMITATIONS OF INSULATION / VENTILATION COMPONENT INSPECTION

As prescribed in the inspection authorization and agreement, this is a visual inspection only. The inspection of insulation and ventilation was limited by (but not restricted to) the following conditions:

- Insulation/ventilation type and levels in concealed areas cannot be determined. No destructive tests are performed.
- Potentially hazardous materials such as Asbestos and Urea Formaldehyde Foam Insulation (UFFI) cannot be positively identified without a detailed inspection and laboratory analysis. This is beyond the scope of the inspection.
- An analysis of indoor air quality is beyond the scope of this inspection.
- Any estimates of insulation R-values or depths are rough average values.
- No access was gained to the wall cavities of the home.

Please refer to the ASHI Inspector Standards for a full explanation of the scope of the inspection.

PLUMBING SYSTEM

DESCRIPTION OF PLUMBING SYSTEM COMPONENTS

Water Supply Source:	●Public Water Supply
Service Pipe to House:	●Copper
Main Valve Location:	●Front Wall of Basement
Supply Piping:	●Copper ●PEX
Gas Valve Location:	●At Meter
Gas Piping:	●Corrugated Stainless Steel Tubing ●Black Pipe
Waste System:	●Public Sewer System
Drain / Waste / Vent Piping:	●PVC
Water Heater Description:	●Model: GS6-40-BCT 400 ●Serial: 2135125924528 ●Manufacture Date: Sep 2021 ●Approximate Age: 5 years
Capacity:	●40 gallon
Water Heater Energy Source:	●Gas

PLUMBING SYSTEM COMPONENT OBSERVATIONS

Positive Attributes

The plumbing system is in generally good condition. The water pressure supplied to the fixtures is reasonably good. A typical drop in flow was experienced when two fixtures were operated simultaneously. The water heater is a relatively new unit. As the typical life expectancy of water heaters is 7 to 12 years, this unit should have several years of remaining life. The plumbing system is in good condition and no leaks were observed in the supply and/ or drainage systems.

RECOMMENDATIONS / OBSERVATIONS

Supply Plumbing

- **Safety Issue:** The hot/cold water supplies are reversed at the sink in the bathroom. This condition represents a potential scald hazard. **See Photo 22**

Hose Bibbs

- **Improve:** The hose bibb at the front of the house is leaky. **See Photo 23**
- **Improve:** The hose bib at the front of the house is loose and should be properly secured. **See Photo 24**

Faucets

- **Improve:** The shower faucet is leaky. **See Photo 25**

Showers

- **Improve:** The shower valve handle has damaged “stops”, allowing the valve to be rotated a full 360 degrees without stopping on full hot or full cold. **See Photo 26**

Waste / Vent

- **Monitor:** The waste standpipe for the washing machine is Rrouted to the floor drain. This should be monitored to ensure proper drainage from washer. If the drain gets clogged the water from washer could backup into the basement. **See Photo 27**

LIMITATIONS OF PLUMBING SYSTEM COMPONENT INSPECTION

As prescribed in the inspection authorization and agreement, this is a visual inspection only. The inspection of the plumbing system was limited by (but not restricted to) the following conditions:

- Portions of the plumbing system concealed by finishes and/or storage (below sinks, etc.), below the structure, and beneath the yard were not inspected.
- Water quality is not tested. The effect of lead content in solder and or supply lines is beyond the scope of the inspection.

Please refer to the ASHI Inspector Standards for a full explanation of the scope of the inspection.

PLUMBING SYSTEM PHOTO SUMMARY



Photo 22: Hot/Cold Supply Reversed.



Photo 23: Hose Bibb Leaky.



Photo 24: Hose Bib Loose .



Photo 25: Faucet Leaky.



Photo 26: Shower Valve Stops Missing.



Photo 27: Waste Standpipe Routed to Floor Drain.

INTERIOR

DESCRIPTION OF INTERIOR COMPONENTS

Wall and Ceiling Finishes:	●Plaster
Floor Surfaces:	●Wood ●Vinyl Plank ●Linoleum
Interior Window Style / Glazing:	●Double Pane Insulated ●Single Pane with Storm Window
	●Double Hung
Doors:	●Wood ●Hollow Core
Fireplaces:	●None

INTERIOR COMPONENT OBSERVATIONS

General Condition of Interior Finishes

There were no signs of previous water damage and/or water penetration into the house. The walls are relatively plumb and in good condition. The ceilings are in good condition. On the whole, the interior finishes of the home are considered to be in average condition. Typical flaws were observed in some areas.

General Condition of Windows and Doors

The majority of the doors are average quality units. The majority of the windows are modest quality units. While there is no rush to substantially improve these windows, replacement window would be a logical long term improvement.

General Condition of Floors

The floors of the home are relatively level and walls are relatively plumb.

RECOMMENDATIONS / OBSERVATIONS

Windows

- **Improve:** The windows are older and in mild disrepair. This is a common condition that does not necessitate immediate major repair. Trimming and adjustment, hardware improvements and glazing repairs would be logical long term improvements. In practice, improvements are usually made on an as needed basis only. The most important factor is that the window exteriors are well maintained to avoid rot or water infiltration. **See Photo 28**
- **Monitor:** A window is painted shut in the kitchen. Improvement can be undertaken as desired. **See Photo 29**

Floors

- **Improve:** Scratches/damage observed to the wood floor was observed in various areas. It should be repaired or replaced as desired. **See Photos 30-34**

LIMITATIONS OF INTERIOR COMPONENT INSPECTION

As prescribed in the inspection authorization and agreement, this is a visual inspection only. Assessing the quality and condition of interior finishes is highly subjective. Issues such as cleanliness, cosmetic flaws, quality of materials, architectural appeal and color are outside the scope of this inspection. Comments will be general, except where functional concerns exist. No comment is offered on the extent of cosmetic repairs that may be needed after removal of existing wall hangings and furniture. The inspection of the interior was limited by (but not restricted to) the following conditions:

- Furniture, storage, appliances and/or wall hangings restricted the inspection of the interior.
- Recent renovations and/or interior painting concealed historical evidence.
- Potentially hazardous substances (such as carbon monoxide, mold, Chinese drywall, etc.) cannot be positively identified without a detailed inspection for these types of substances and a laboratory analysis. This is beyond the scope of a home inspection.

Please refer to the ASHI Inspector Standards for a full explanation of the scope of the inspection.

INTERIOR PHOTO SUMMARY



Photo 28: Old Windows - Mild Disrepair.



Photo 29: Window Painted Shut.



Photo 30: Wood Floor Damage.



Photo 31: Wood Floor Damage.



Photo 32: Wood Floor Damage.



Photo 33: Wood Floor Damage.



Photo 34: Wood Floor Damage.

APPLIANCES

DESCRIPTION OF APPLIANCES COMPONENTS

Appliances Tested:	●Gas Range ●Refrigerator
Laundry Facility:	●240 Volt Circuit for Dryer ●Dryer Vents to Building Exterior ●120 Volt Circuit for Washer ●Hot/Cold Water Supply for Washer ●Washer drains to floor drain
Other Components Tested:	●Kitchen Exhaust Fan

APPLIANCES COMPONENT OBSERVATIONS

Positive Attributes

Most of the major appliances in the home are newer. The appliances are considered to be in generally good condition. Most appliances that were tested responded satisfactorily. The kitchen cabinetry is in good condition and the cabinets have been well maintained. The kitchen countertops appear to be in good condition and have been well maintained.

RECOMMENDATIONS / OBSERVATIONS

Refrigerator

- **Improve:** There is evidence of leakage from the refrigerator. Further review by a service technician is recommended. **See Photo 35**
- **Improve:** The refrigerator door gasket should be improved. **See Photo 36**

Door Bell

- **Improve:** The door bell is inoperative. **See Photo 37**

LIMITATIONS OF APPLIANCES COMPONENT INSPECTION

As prescribed in the inspection authorization and agreement, this is a visual inspection only. Appliances are tested by turning them on for a short period of time only. It is strongly recommended that a Homeowner's Warranty or service contract be purchased to cover the operation of appliances. It is further recommended that appliances be tested during any scheduled pre-closing walk through. Like any mechanical device, appliances can malfunction at any time (including the day after taking possession of the house). The inspection of the appliances was limited by (but not restricted to) the following conditions:

- Thermostats, timers and other specialized features and controls are not tested.
- The effectiveness, efficiency and overall performance of appliances are outside the scope of this inspection.

Please refer to the ASHI Inspector Standards for a full explanation of the scope of the inspection.

APPLIANCES PHOTO SUMMARY



Photo 35: Refrigerator Leakage.



Photo 36: Door Gasket Poor.

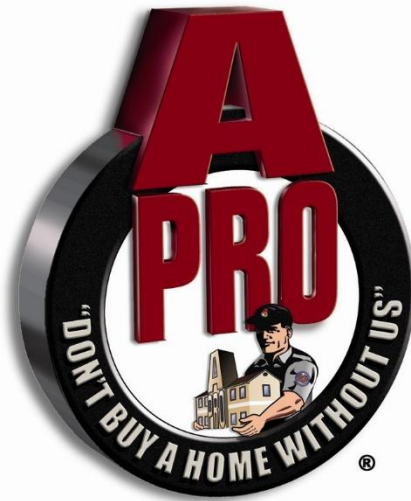

Photo 37: Door Bell Inoperative.

THANK YOU!

It has been a pleasure working with you and we hope you think of us for your future inspection needs. As with all A-PRO inspections, yours was performed by a certified home inspector (CHI) under the strict guidelines of ASHI.

Please understand that there are limitations to such an inspection. The report does not reflect the results of an exhaustive technical evaluation, but rather a visual inspection. The distinction between the two is important. A technical evaluation requires exhaustive testing and analysis of a house's parts, taking more time and costing significantly more money. Our inspection does not consider components in the home that are not visible. Also understand that, even with an exhaustive inspection, there still may be defects in the home that are not revealed during the inspection. A visual inspection provides you with a solid, overall picture of the home, its problems, positive attributes, and areas where we recommended immediate attention. But with anything as complex as a home (a home has roughly 500 separate components), unexpected repairs are the norm, not the exception.



**It Takes A-Pro to Know...
Don't Buy a Home Without Us!**

MAINTENANCE ADVICE

UPON TAKING OWNERSHIP

After taking possession of a new home, there are some maintenance and safety issues that should be addressed immediately. The following checklist should help you undertake these improvements:

- Change the locks on all exterior entrances, for improved security.
- Check that all windows and doors are secure. Improve window hardware as necessary. Security rods can be added to sliding windows and doors. Consideration could also be given to a security system.
- Install smoke detectors on each level of the home. Ensure that there is a smoke detector outside all sleeping areas. Replace batteries on any existing smoke detectors and test them. Make a note to replace batteries again in one year.
- Create a plan of action in the event of a fire in your home. Ensure that there is an operable window or door in every room of the house. Consult with your local fire department regarding fire safety issues and what to do in the event of fire.
- Examine driveways and walkways for trip hazards. Undertake repairs where necessary.
- Examine the interior of the home for trip hazards. Loose or torn carpeting and flooring should be repaired.
- Undertake improvements to all stairways, decks, porches and landings where there is a risk of falling or stumbling.
- Review your home inspection report for any items that require immediate improvement or further investigation. Address these areas as required.
- Install rain caps and vermin screens on all chimney flues, as necessary.
- Investigate the location of the main shut-offs for the plumbing, heating and electrical systems. If you attended the home inspection, these items would have been pointed out to you.

REGULAR MAINTENANCE

EVERY MONTH

- Check that fire extinguisher(s) are fully charged. Re-charge if necessary.
- Examine heating/cooling air filters and replace or clean as necessary.
- Inspect and clean humidifiers and electronic air cleaners.
- If the house has hot water heating, bleed radiator valves.
- Clean gutters and downspouts. Ensure that downspouts are secure, and that the discharge of the downspouts is appropriate. Remove debris from window wells.
- Carefully inspect the condition of shower enclosures. Repair or replace deteriorated grout and caulk. Ensure that water is not escaping the enclosure during showering. Check below all plumbing fixtures for evidence of leakage.
- Repair or replace leaking faucets or showerheads.
- Secure loose toilets, or repair flush mechanisms that become troublesome.

SPRING AND FALL

- Examine the roof for evidence of damage to roof coverings, flashings and chimneys.
- Look in the attic (if accessible) to ensure that roof vents are not obstructed. Check for evidence of leakage, condensation or vermin activity. Level out insulation if needed.
- Trim back tree branches and shrubs to ensure that they are not in contact with the house.
- Inspect the exterior walls and foundation for evidence of damage, cracking or movement. Watch for bird nests or other vermin or insect activity.
- Survey the basement and/or crawl space walls for evidence of moisture seepage.

- Look at overhead wires coming to the house. They should be secure and clear of trees or other obstructions.
- Ensure that the grade of the land around the house encourages water to flow away from the foundation.
- Inspect all driveways, walkways, decks, porches, and landscape components for evidence of deterioration, movement or safety hazards.
- Clean windows and test their operation. Improve caulking and weather-stripping as necessary. Watch for evidence of rot in wood window frames. Paint and repair windowsills and frames as necessary.
- Test all ground fault circuit interrupter (GFCI) devices, as identified in the inspection report.
- Shut off isolating valves for exterior hose bibs in the fall, if below freezing temperatures are anticipated.
- Test the Temperature and Pressure Relief (TPR) Valve on water heaters.
- Inspect for evidence of wood boring insect activity. Eliminate any wood/soil contact around the perimeter of the home.
- Test the overhead garage door opener, to ensure that the auto-reverse mechanism is responding properly. Clean and lubricate hinges, rollers and tracks on overhead doors.
- Replace or clean exhaust hood filters.
- Clean, inspect and/or service all appliances as per the manufacturer's recommendations.

ANNUALLY

- Replace smoke detector batteries.
- Have the heating, cooling and water heater systems cleaned and serviced.
- Have chimneys inspected and cleaned. Ensure that rain caps and vermin screens are secure.
- Examine the electrical panels, wiring and electrical components for evidence of overheating. Ensure that all components are secure. Flip the breakers on and off to ensure that they are not sticky.
- If the house utilizes a well, check and service the pump and holding tank. Have the water quality tested. If the property has a septic system, have the tank inspected (and pumped as needed).
- If your home is in an area prone to wood destroying insects (termites, carpenter ants, etc.), have the home inspected by a licensed specialist. Preventative treatments may be recommended in some cases.

PREVENTION IS THE BEST APPROACH

Although we've heard it many times, nothing could be more true than the old cliché "an ounce of prevention is worth a pound of cure." Preventative maintenance is the best way to keep your house in great shape. It also reduces the risk of unexpected repairs and improves the odds of selling your house at fair market value, when the time comes.

Please feel free to contact our office should you have any questions regarding the operation or maintenance of your home.

Enjoy your home!

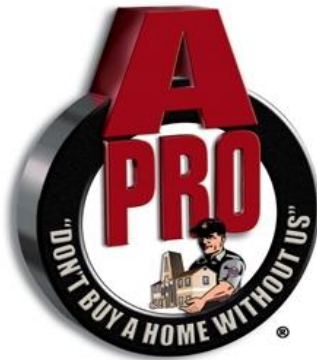

THE A-PRO HOME MAINTENANCE CHECKLIST

So you've just moved into your new home. You shopped around and did a lot of research to find the home that was just right for you. You signed a big pile of documents at closing, the moving trucks have left, all the boxes are unpacked, and all your belongings are in their proper places. What should you do now?

One of the most important things to remember is that you are responsible for certain routine maintenance items to keep your house functioning properly. These tasks tend to be relatively simple. For instance, many types of heating and air conditioning systems contain filters to remove dirt and dust from the air. A homeowner should change these filters when necessary.

Cleanliness is a factor that will make your home last longer and work better. Dust and dirt, if allowed to accumulate, can harm the finishes on blinds, cabinets, countertops, floors, sinks, tubs, toilets, walls, tiles and other items. If dirt does accumulate, make sure to clean it with a substance that does not scratch or damage the finishes.

On the outside of your home, make sure that gutters and downspouts do not get clogged with leaves or other objects. The exterior of your house is built to withstand exposure to the elements, but a periodic cleaning will improve the appearance and, in many instances, prolong the life of siding and other exterior products.

Note: The following pages are a list of maintenance reminders; things you should take care of on a regular basis along with one-time tasks. It's a good idea to review the list from time to time, in order to make sure you're taking proper care of your property.

Task	Task Frequency	Person Assigned	Date last completed
Ongoing			
Test smoke detectors	Monthly		
Mechanical water softener	See manual		
Drain off sediment from base of hot water tank	Monthly		
Quarterly			
Check faucets for leaks. Clean aerators. Replace worn washers.	Quarterly		
Inspect bathtubs and sinks for caulking and leaks; repair as needed	Quarterly		
Clean drains with baking soda. Pour water down unused drains.	Quarterly		
Inspect visible pipes for leaks	Quarterly		
Check under and around cabinets for leaks	Quarterly		
Check toilets for stability and leaks	Quarterly		
Check area around water heater for leaks. If you have hard water, drain 1-2 gallons of water	Quarterly		
Apply wood protectant to cabinets and trim	Quarterly		
Lubricate hinges of interior doors	Quarterly		
Lubricate hardware on garage doors and inspect for damage	Quarterly		
Clean out dirt and dust from window and door tracks. Lubricate rollers and latches	Quarterly		
Check for cracks, dampness and leaks in basement and crawl space. Check for any evidence of termites or wood eating insects	Quarterly		
Clean and grout ceramic tile	Quarterly		
Survey carpet and flooring and clean as needed or quarterly	Quarterly		
Check operation of water pump and sump pump, if applicable	Quarterly		
Vacuum under refrigerator and dust condenser	Quarterly		
Turn mattress, wash mattress covers	Quarterly		
Defrost manual refrigerator; or if automatically defrosted, wash off shelves and clean when frost is 1/4" thick	Quarterly		
Clean oven	Quarterly		
Major cleaning	Quarterly		
Review emergency procedures and practice fire drill	Quarterly		

Task	Task Frequency	Person Assigned	Date last completed
Winter Maintenance Schedule			
Change furnace filters	Monthly during heating season		
Humidifier: thoroughly clean water in reservoir	Weekly		
Chimney cleaned for wood stove/fireplace	As needed		
Spring Maintenance Schedule			
Remove and store windows and doors	Annually		
Window cleaning spring and fall	As needed		
Window caulking (especially for air-conditioned rooms)	Spring and fall or as needed		
Plans for outside care, such as washing or painting siding	Annually as needed		
Air winter coverlets and bedding before storage	Annually		
Summer Maintenance Schedule			
Clean air conditioner filter	Monthly or as per manual directions		
Clean home pantry area, arrange items on hand, and prepare space for additions	Annually		
Fall Maintenance Schedule			
Heating system services before system is needed	Annually		
Chimney cleaned for wood stove	See manual		
Remove leaves from gutters	Once or twice during fall		
Clean and store yard tools, discard or store yard chemicals properly	As needed		
Clean fire extinguisher, refill or replace as needed	Annually		
Turn off water to outside faucets (this is not necessary on those with extended line)	Annually		
Sort, clean, pack, and store holiday items	Annually		

ASHI STANDARD OF PRACTICE FOR HOME INSPECTIONS

1. INTRODUCTION

The American Society of Home Inspectors®, Inc. (ASHI®) is a not-for-profit professional society established in 1976. Membership in ASHI is voluntary and its members are private home inspectors. ASHI's objectives include promotion of excellence within the profession and continual improvement of its members' inspection services to the public.

2. PURPOSE AND SCOPE

2.1 The purpose of this document is to establish a minimum standard (Standard) for home inspections performed by home inspectors who subscribe to this Standard. Home inspections performed using this Standard are intended to provide the client with information about the condition of inspected systems and components at the time of the home inspection.

2.2 The inspector shall:

- A. inspect readily accessible, visually observable, installed systems and components listed in this Standard.
- B. provide the client with a written report, using a format and medium selected by the inspector, that states:
 - 1. those systems and components inspected that, in the professional judgment of the inspector, are not functioning properly, significantly deficient, unsafe, or are near the end of their service lives,
 - 2. recommendations to correct, or monitor for future correction, the deficiencies reported in 2.2.B.1, or items needing further evaluation (Per Exclusion 13.2.A.5 the inspector is NOT required to determine methods, materials, or costs of corrections.),
 - 3. reasoning or explanation as to the nature of the deficiencies reported in 2.2.B.1, that are not self-evident,
 - 4. those systems and components designated for inspection in this Standard that were present at the time of the home inspection but were not inspected and the reason(s) they were not inspected.
- C. adhere to the ASHI® Code of Ethics for the Home Inspection Profession.

2.3 This Standard is not intended to limit the inspector from:

- A. including other services or systems and components in addition to those required in Section 2.2.A.
- B. designing or specifying repairs, provided the inspector is appropriately qualified and willing to do so.
- C. excluding systems and components from the inspection if requested or agreed to by the client.

3. STRUCTURAL COMPONENTS

3.1 The inspector shall:

- A. inspect structural components including the foundation and framing.
- B. describe:
 - 1. the methods used to inspect under-floor crawlspaces and attics.
 - 2. the foundation.
 - 3. the floor structure.
 - 4. the wall structure.
 - 5. the ceiling structure.
 - 6. the roof structure.

3.2 The inspector is NOT required to:

- A. provide engineering or architectural services or analysis.
- B. offer an opinion about the adequacy of structural systems and components.
- C. enter under-floor crawlspace areas that have less than 24 inches of vertical clearance between components and the ground or that have an access opening smaller than 16 inches by 24 inches.
- D. traverse attic load-bearing components that are concealed by insulation or by other materials.

4. EXTERIOR

4.1 The inspector shall:

- A. inspect:
 1. wall coverings, flashing, and trim.
 2. exterior doors.
 3. attached and adjacent decks, balconies, stoops, steps, porches, and their associated railings.
 4. eaves, soffits, and fascia's where accessible from the ground level.
 5. vegetation, grading, surface drainage, and retaining walls that are likely to adversely affect the building.
 6. adjacent and entryway walkways, patios, and drive- ways.
- B. describe wall coverings.

4.2 The inspector is NOT required to inspect:

- A. screenings, shutters, awnings, and similar seasonal accessories.
- B. fences, boundary walls, and similar structures.
- C. geological and soil conditions.
- D. recreational facilities.
- E. outbuildings other than garages and carports.
- F. seawalls, break-walls, and docks.
- G. erosion control and earth stabilization measures.

5. ROOFING

5.1 The inspector shall:

- A. inspect:
 1. roofing materials.
 2. roof drainage systems.
 3. flashing.
 4. skylights, chimneys, and roof penetrations.
- B. describe:
 1. roofing materials.
 2. methods used to inspect the roofing.

5.2 The inspector is NOT required to inspect:

- A. antennas.
- B. interiors of vent systems, flues, and chimneys that are not readily accessible.
- C. other installed accessories.

6. PLUMBING

6.1 The inspector shall:

- A. inspect:
 1. interior water supply and distribution systems including fixtures and faucets.
 2. interior drain, waste, and vent systems including fixtures.
 3. water heating equipment and hot water supply systems.
 4. vent systems, flues, and chimneys.
 5. fuel storage and fuel distribution systems.
 6. sewage ejectors, sump pumps, and related piping.
- B. describe:
 1. interior water supply, drain, waste, and vent piping materials.
 2. water heating equipment including energy source(s).
 3. location of main water and fuel shut-off valves.

6.2 The inspector is NOT required to:

- A. inspect:
 1. clothes washing machine connections.
 2. interiors of vent systems, flues, and chimneys that are not readily accessible.
 3. wells, well pumps, and water storage related equipment.
 4. water conditioning systems.
 5. solar, geothermal, and other renewable energy water heating systems.
 6. manual and automatic fire extinguishing and sprinkler systems and landscape irrigation systems.
 7. septic and other sewage disposal systems.

- B. determine:
 1. whether water supply and sewage disposal are public or private.
 2. water quality.
 3. the adequacy of combustion air components.
- C. measure water supply flow and pressure, and well water quantity.
- D. fill shower pans and fixtures to test for leaks.

7. ELECTRICAL

7.1 The inspector shall:

- A. inspect:
 1. service drop.
 2. service entrance conductors, cables, and raceways.
 3. service equipment and main disconnects.
 4. service grounding.
 5. interior components of service panels and subpanels.
 6. conductors.
 7. overcurrent protection devices.
 8. a representative number of installed lighting fixtures, switches, and receptacles.
 9. ground fault circuit interrupters and arc fault circuit interrupters.
- B. describe:
 1. amperage rating of the service.
 2. location of main disconnect(s) and subpanels.
 3. presence or absence of smoke alarms and carbon monoxide alarms.
 4. the predominant branch circuit wiring method.

7.2 The inspector is NOT required to:

- A. inspect:
 1. remote control devices.
 2. or test smoke and carbon monoxide alarms, security systems, and other signaling and warning devices.
 3. low voltage wiring systems and components.
 4. ancillary wiring systems and components not a part of the primary electrical power distribution system.
 5. solar, geothermal, wind, and other renewable energy systems.
- B. measure amperage, voltage, and impedance.
- C. determine the age and type of smoke alarms and carbon monoxide alarms

8. HEATING

8.1 The inspector shall:

- A. open readily openable access panels.
- B. inspect:
 1. installed heating equipment.
 2. vent systems, flues, and chimneys.
 3. distribution systems.
- C. describe:
 1. energy source(s).
 2. heating systems.

8.2 The inspector is NOT required to:

- A. inspect:
 1. interiors of vent systems, flues, and chimneys that are not readily accessible.
 2. heat exchangers.
 3. humidifiers and dehumidifiers.
 4. electric air cleaning and sanitizing devices.
 5. heating systems using ground-source, water-source, solar, and renewable energy technologies.
 6. heat-recovery and similar whole-house mechanical ventilation systems.
- B. determine:
 1. heat supply adequacy and distribution balance.

2. the adequacy of combustion air components.

9. AIR CONDITIONING

9.1 The inspector shall:

- A. open readily openable access panels.
- B. inspect:
 1. central and permanently installed cooling equipment.
 2. distribution systems.
- C. describe:
 1. energy source(s).
 2. cooling systems.

9.2 The inspector is NOT required to:

- A. inspect electric air cleaning and sanitizing devices.
- B. determine cooling supply adequacy and distribution balance.
- C. inspect cooling units that are not permanently installed or that are installed in windows.
- D. inspect cooling systems using ground-source, water-source, solar, and renewable energy technologies.

10. INTERIORS

10.1 The inspector shall inspect:

- A. walls, ceilings, and floors.
- B. steps, stairways, and railings.
- C. countertops and a representative number of installed cabinets.
- D. a representative number of doors and windows.
- E. garage vehicle doors and garage vehicle door operators.
- F. installed ovens, ranges, surface cooking appliances, microwave ovens, dishwashing machines, and food waste grinders by using normal operating controls to activate the primary function.

10.2 The inspector is NOT required to inspect:

- A. paint, wallpaper, and other finish treatments.
- B. floor coverings.
- C. window treatments.
- D. coatings on and the hermetic seals between panes of window glass.
- E. central vacuum systems.
- F. recreational facilities.
- G. installed, and free-standing kitchen and laundry appliances not listed in Section 10.1.F.
- H. appliance thermostats including their calibration, adequacy of heating elements, self-cleaning oven cycles, indicator lights, door seals, timers, clocks, timed features, and other specialized features of the appliance.
- I. operate or confirm the operation of every control and feature of an inspected appliance.

11. INSULATION AND VENTILATION

11.1 The inspector shall:

- A. inspect:
 1. insulation and vapor retarders in unfinished spaces.
 2. ventilation of attics and foundation areas.
 3. kitchen, bathroom, laundry, and similar exhaust systems.
 4. clothes dryer exhaust systems.
- B. describe:
 1. insulation and vapor retarders in unfinished spaces.
 2. absence of insulation in unfinished spaces at conditioned surfaces.

11.2 The inspector is NOT required to disturb insulation.

12. FIREPLACES AND FUEL-BURNING APPLIANCES

12.1 The inspector shall:

- A. inspect:
 1. fuel-burning fireplaces, stoves, and fireplace inserts.
 2. fuel-burning accessories installed in fireplaces.
 3. chimneys and vent systems.

B. describe systems and components listed in 12.1.A.1 and .2.

12.2 The inspector is NOT required to:

- A. inspect:
 1. interiors of vent systems, flues, and chimneys that are not readily accessible.
 2. fire screens and doors.
 3. seals and gaskets.
 4. automatic fuel feed devices.
 5. mantles and fireplace surrounds.
 6. combustion air components and to determine their adequacy.
 7. heat distribution assists (gravity fed, and fan assisted).
 8. fuel-burning fireplaces and appliances located out- side the inspected structures.
- B. determine draft characteristics.
- C. move fireplace inserts and stoves or firebox contents.

13. GENERAL LIMITATIONS AND EXCLUSIONS

13.1 General limitations

- A. The inspector is NOT required to perform actions, or to make determinations, or to make recommendations not specifically stated in this Standard.
- B. Inspections performed using this Standard:
 1. are not technically exhaustive.
 2. are not required to identify and to report:
 - a. concealed conditions, latent defects, consequential damages, and
 - b. cosmetic imperfections that do not significantly affect a component's performance of its intended function.
- C. This Standard applies to buildings with four or fewer dwelling units and their attached and detached garages and carports.
- D. This Standard shall not limit or prevent the inspector from meeting state statutes which license professional home inspection and home inspectors.
- E. Redundancy in the description of the requirements, limitations, and exclusions regarding the scope of the home inspection is provided for emphasis only.

13.2 General exclusions

- A. The inspector is NOT required to determine:
 1. the condition of systems and components that are not readily accessible.
 2. the remaining life expectancy of systems and components.
 3. the strength, adequacy, effectiveness, and efficiency of systems and components.
 4. the causes of conditions and deficiencies.
 5. methods, materials, and costs of corrections.
 6. future conditions including but not limited to failure of systems and components.
 7. the suitability of the property for specialized uses.
 8. compliance of systems and components with past and present requirements and guidelines (codes, regulations, laws, ordinances, specifications, installation and maintenance instructions, use and care guides, etc.).
 9. the market value of the property and its marketability.
 10. the advisability of purchasing the property.

11. the presence of plants, animals, and other life forms and substances that may be hazardous or harmful to humans including, but not limited to, wood destroying organisms, molds and mold-like substances.
 12. the presence of environmental hazards including, but not limited to, allergens, toxins, carcinogens, electro- magnetic radiation, noise, radioactive substances, and contaminants in building materials, soil, water, and air.
 13. the effectiveness of systems installed, and methods used to control or remove suspected hazardous plants, animals, and environmental hazards.
 14. operating costs of systems and components.
 15. acoustical properties of systems and components.
 16. soil conditions relating to geotechnical or hydrologic specialties.
 17. whether items, materials, conditions and components are subject to recall, controversy, litigation, product liability, and other adverse claims and conditions.
- B. The inspector is NOT required to offer:
1. or to perform acts or services contrary to law or to government regulations.
 2. or to perform architectural, engineering, contracting, or surveying services or to confirm or to evaluate such services performed by others.
 3. or to perform trades or professional services other than home inspection.
 4. warranties or guarantees.
- C. The inspector is NOT required to operate:
1. systems and components that are shut down or otherwise inoperable.
 2. systems and components that do not respond to normal operating controls.
 3. shut-off valves and manual stop valves.
 4. automatic safety controls.
- D. The inspector is NOT required to enter:
1. areas that will, in the professional judgment of the inspector, likely be dangerous to the inspector or to other persons, or to damage the property or its systems and components.
 2. under-floor crawlspaces and attics that are not readily accessible.
- E. The inspector is NOT required to inspect:
1. underground items including, but not limited to, underground storage tanks and other underground indications of their presence, whether abandoned or active.
 2. items that are not installed.
 3. installed decorative items.
 4. items in areas that are not entered in accordance with 13.2.D.
 5. detached structures other than garages and carports.
 6. common elements and common areas in multi- unit housing, such as condominium properties and cooperative housing.
 7. every occurrence of multiple similar components.
 8. outdoor cooking appliances.
- F. The inspector is NOT required to:
1. perform procedures or operations that will, in the professional judgment of the inspector, likely be dangerous to the inspector or to other persons, or to damage the property or its systems or components.
 2. describe or report on systems and components that are not included in this Standard and that were not inspected.
 3. move personal property, furniture, equipment, plants, soil, snow, ice, and debris.
 4. dismantle systems and components, except as explicitly required by this Standard.
 5. reset, reprogram, or otherwise adjust devices, systems, and components affected by inspection required by this Standard.
 6. ignite or extinguish fires, pilot lights, burners, and other open flames that require manual ignition.
 7. probe surfaces that would be damaged or where no deterioration is visible or presumed to exist.

14. GLOSSARY OF TERMS

Automatic Safety Controls: Devices designed and installed to protect systems and components from unsafe conditions

Component: A part of a system

Decorative: Ornamental; not required for the proper operation of the essential systems and components of a home

Describe: To identify (in writing) a system and component by its type or other distinguishing characteristics

Dismantle: To take apart or remove components, devices, or pieces of equipment that would not be taken apart or removed by a homeowner in the course of normal maintenance

Engineering: The application of scientific knowledge for the design, control, or use of building structures, equipment, or apparatus

Further Evaluation: Examination and analysis by a qualified professional, tradesman, or service technician beyond that provided by a home inspection

Home Inspection: The process by which an inspector visually examines the readily accessible systems and components of a home and describes those systems and components using this Standard

Inspect: The process of examining readily accessible systems and components by (1) applying this Standard, and (2) operating normal operating controls, and (3) opening readily openable access panels

Inspector: A person hired to examine systems and components of a building using this Standard

Installed: Attached such that removal requires tools

Normal Operating Controls: Devices such as thermostats, switches, and valves intended to be operated by the homeowner

Readily Accessible: Available for visual inspection without requiring moving of personal property, dismantling, destructive measures, or actions that will likely involve risk to persons or property

Readily Openable Access Panel: A panel provided for homeowner inspection and maintenance that is readily accessible, within normal reach, can be opened by one person, and is not sealed in place

Recreational Facilities: Spas, saunas, steam baths, swimming pools, exercise, entertainment, athletic, playground and other similar equipment, and associated accessories

Representative Number: One component per room for multiple similar interior components such as windows and electric receptacles; one component on each side of the building for multiple similar exterior components

Roof Drainage Systems: Components used to carry water off a roof and away from a building

Shut Down: A state in which a system or component cannot be operated by normal operating controls

Structural Component: A component that supports non-variable forces or weights (dead loads) and variable forces or weights (live loads)

System: A combination of interacting or interdependent components, assembled to carry out one or more functions

Technically Exhaustive: An investigation that involves dismantling, the extensive use of advanced techniques, measurements, instruments, testing, calculations, or other means

Under-floor Crawlspace: The area within the confines of the foundation and between the ground and the underside of the floor

Unsafe: A condition in a readily accessible, installed system or component that is judged by the inspector to be a significant risk of serious bodily injury during normal, day-to-day use; the risk may be due to damage, deterioration, improper installation, or a change in accepted residential construction practices

Wall Covering: A protective or insulating layer fixed to the outside of a building such as: aluminum, brick, EIFS, stone, stucco, vinyl, and wood

Wiring Method: Identification of electrical conductors or wires by their general type, such as non-metallic sheathed cable, armored cable, and knob and tube, etc.

ASHI® CODE OF ETHICS

For the Home Inspection Profession

Integrity, honesty, and objectivity are fundamental principles embodied by this Code, which sets forth obligations of ethical conduct for the home inspection profession. The Membership of ASHI has adopted this Code to provide high ethical standards to safeguard the public and the profession.

Inspectors shall comply with this Code, shall avoid association with any enterprise whose practices violate this Code, and shall strive to uphold, maintain, and improve the integrity, reputation, and practice of the home inspection profession.

1. Inspectors shall avoid conflicts of interest or activities that compromise, or appear to compromise, professional independence, objectivity, or inspection integrity.
 - A. Inspectors shall not inspect properties for compensation in which they have, or expect to have, a financial interest.
 - B. Inspectors shall not inspect properties under contingent arrangements whereby any compensation or future referrals are dependent on reported findings or on the sale of a property.
 - C. Inspectors shall not directly or indirectly compensate realty agents, or other parties having a financial interest in closing or settlement of real estate transactions, for the referral of inspections or for inclusion on a list of recommended inspectors, preferred providers, or similar arrangements.
 - D. Inspectors shall not receive compensation for an inspection from more than one party unless agreed to by the client(s).
 - E. Inspectors shall not accept compensation, directly or indirectly, for recommending contractors, services, or products to inspection clients or other parties having an interest in inspected properties.
 - F. Inspectors shall not repair, replace, or upgrade, for compensation, systems or components covered by ASHI Standards of Practice, for one year after the inspection.

2. Inspectors shall act in good faith toward each client and other interested parties.
 - A. Inspectors shall perform services and express opinions based on genuine conviction and only within their areas of education, training, or experience.
 - B. Inspectors shall be objective in their reporting and not knowingly understate or overstate the significance of reported conditions.
 - C. Inspectors shall not disclose inspection results or client information without client approval. Inspectors, at their discretion, may disclose observed immediate safety hazards to occupants exposed to such hazards, when feasible.

3. Inspectors shall avoid activities that may harm the public, discredit themselves, or reduce public confidence in the profession.
 - A. Advertising, marketing, and promotion of inspectors' services or qualifications shall not be fraudulent, false, deceptive, or misleading.
 - B. Inspectors shall report substantive and willful violations of this Code to the Society.

ASHI Standard of Practice for Home Inspections Effective March 1, 2014 © Copyright 2014 American Society of Home Inspectors, Inc.® All rights reserve



HOME MAINTENANCE GUIDE



OVERVIEW

The old maxim about “an ounce of prevention” is especially fitting when applied to home maintenance. The first advantage of the preventive approach? Cost efficiency. Instead of getting something repaired in an eleventh-hour panic and probably overpaying for the job, you’ll be prepared. In short, it pays to prepare for repair.

Secondly, the preventive approach stretches home-component life expectancy and thus helps in delaying costly repairs or in sidestepping them altogether. Added advantage: Energy consumption is frequently curbed.

How often should you perform check-ups? In most instances, maintenance inspections should be executed twice a year—in the spring and fall. Naturally some elements need to be checked more often, some less often. (We’ll detail the exceptions as we cover each element.) Remember, too, to keep a record of all inspections as well as all repair work. And if you’re not the kind of personality likely to remember to abide by a regular inspection schedule, don’t be shy about hiring a handyman to do it for you.

Now, let’s cover all the areas of the home that require regular inspection. We’ve organized the information in the following categories:

1. **Structural**
2. **Interior**
3. **Exterior**
4. **Heating & Cooling**
5. **Electrical**
6. **Plumbing**
7. **Attic**
8. **Pest Control**

We’ve also included a home-maintenance checklist, formulated to help you remember many of the tasks involved in proper care.

STRUCTURAL

Wall/ Ceiling Surface Cracks: Don’t be surprised if you notice minor movement of cracks owing to normal settling and shrinkage. But if your monitoring turns up dramatic movement, be alerted that repair may be in order.

Wood Framing: Insect infestation and rot are the two archenemies of your basement’s exposed wooden structural components. You can usually tell if these threats are present if the components are sagging.

Foundation Walls: A certain amount of dampness (owing to creeping moisture) - and thus some deterioration- is to be expected in older foundation walls. Be sure to fill any cracks and voids so that you can monitor any movement between twice-a-year inspections. Note: Make sure to provide access hatches to all crawl space areas.

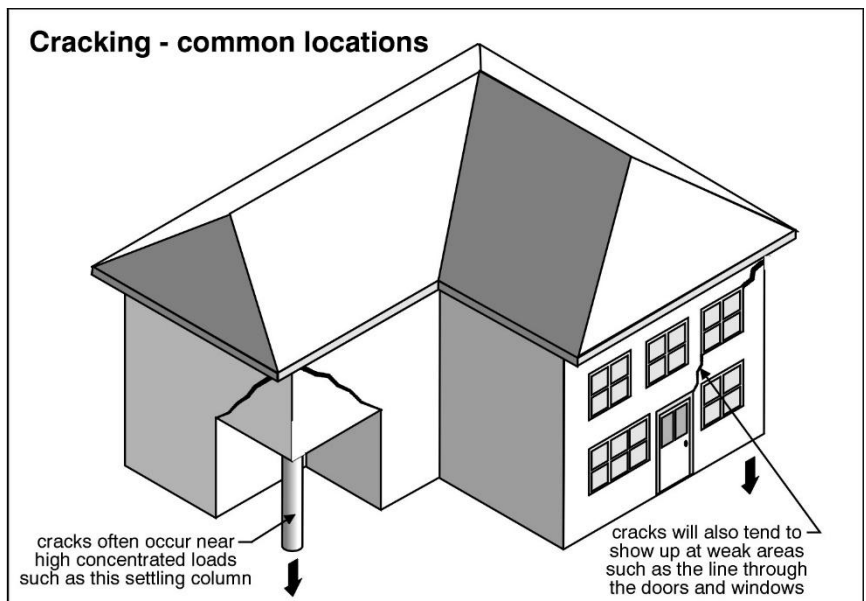

INTERIOR

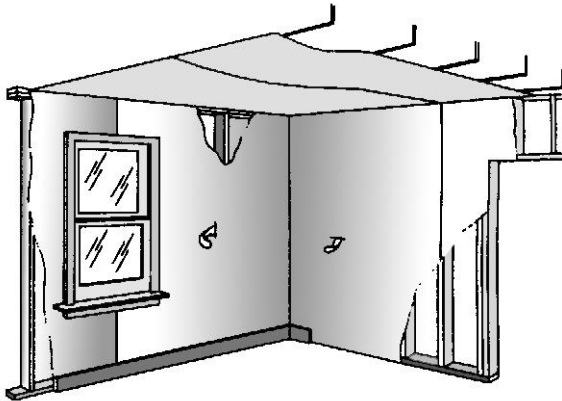

Walls and Ceilings: Both should be inspected for bulges, separated plaster (especially on ceilings where it can be a safety hazard) and for cracks in interior finishes. Always make a record of movement so this condition can be monitored.

Walls in particular should be examined for evidence of mildew or condensation—especially in “dead air” sections (e.g. behind drapes) as well as for water stains. Take note of any movement. If it’s significant and/or a source of the problem is undetectable, repair may be in order.

Door Frames: In examining these every six months, look for the corners to be at perfect right angles. If there is movement of any severity, you may be facing some significant problems.

Windows: In wintertime, check for condensation. It’s a telltale sign of high humidity, which often is a foreshadowing of rot damage.

Fireplaces and Chimneys: If either of these is used with any degree of frequency, you should have them cleaned every year.

EXTERIOR

Damaged and patched flat roofs

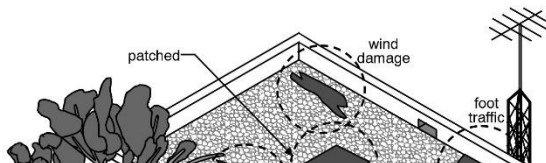

Flat Roofs: These surfaces are vulnerable to blisters, bubbles, flawed flashing details and—in the case of tar and gravel roofs--gravel erosion. Inspect for any of these defects and clear any tree branches touching the surface

Dormer gutters - discharging onto roof

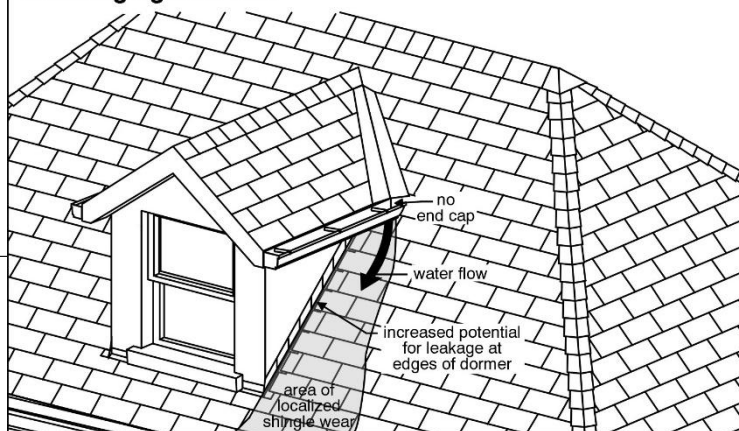

Shingle Roofs: With special emphasis on areas of high wear (e.g. where downspouts discharge from upper to lower roof, or where foot traffic is prevalent), the roof should be thoroughly scrutinized for loose, damaged or missing shingles. The same goes for flashings at plumbing stacks, dormers or similar areas as well as supports for satellite dishes and TV antennas. And to prevent damage to the surface, make sure to cut back tree branches. Furthermore, check that all electric cables are correctly powered and firmly secured.

Gutters & Downspouts: Examine both gutters and downspouts for leakage from joints and rust holes, and to detect blockage and paint deterioration. Check out any areas that may need to be re-sloped or re-secured. Downspouts: Make sure to check for split seams, a condition which often clogs downspouts with debris.

Eaves: Review fascia and soffits to uncover rotted, loose, vermin-damaged or degraded-paint surfaces.

Chimneys: Here's what to look for: Loose or eroding bricks and mortar; loose or broken sections on caps; leakage to flashings; cracks or loose sections on parging or stucco; rust, missing rain caps and loose braces on metal. Make sure there's no efflorescence (white salt build-up), since this is a sign of moisture inside the chimney. If it occurs, have the chimney examined by a professional.

Walls: Masonry walls should be investigated for disintegrating brick and mortar; wood walls for boards that are loose, damaged or rotting; stucco walls for separating and cracking; metal, vinyl, insulbrick and shingle sidings for mechanical damage and loose or missing parts. Whatever the wall surface, be sure to search for any hints of settling.

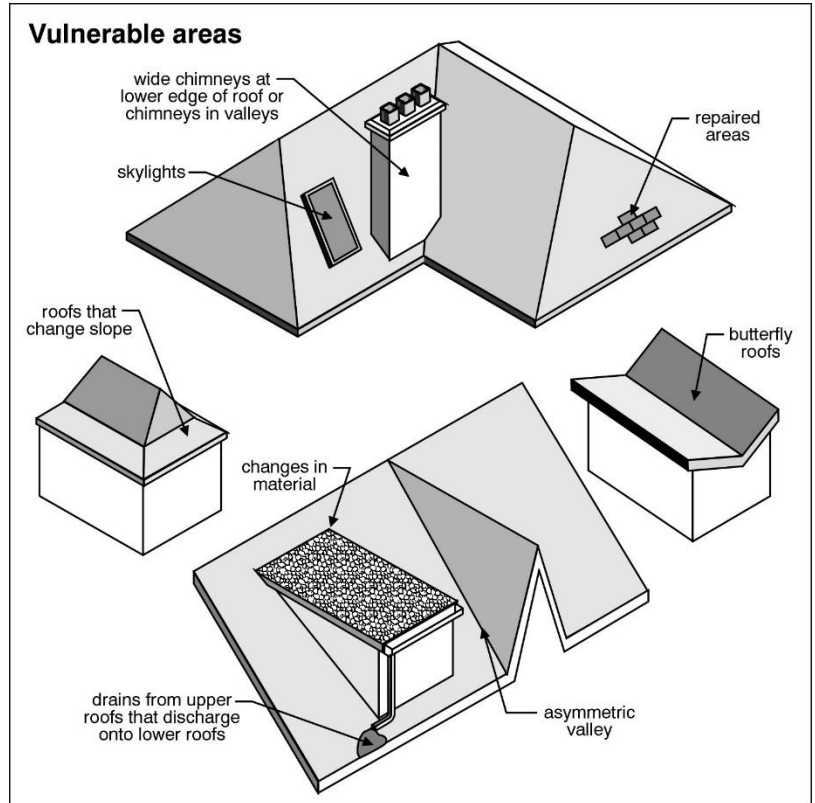

Any blistering or bubbling of paint should be noted and the cause ferreted out. Often these defects are engendered by the spread of moisture from inside the house and could be a foretelling of more serious problems.

Vines? Inspect for wall-surface damage, cut back foliage from doors, windows, gutters, eaves, etc. and maintain trimmed vines. Deciduous vines? Monitor them during winter months when they are defoliated.

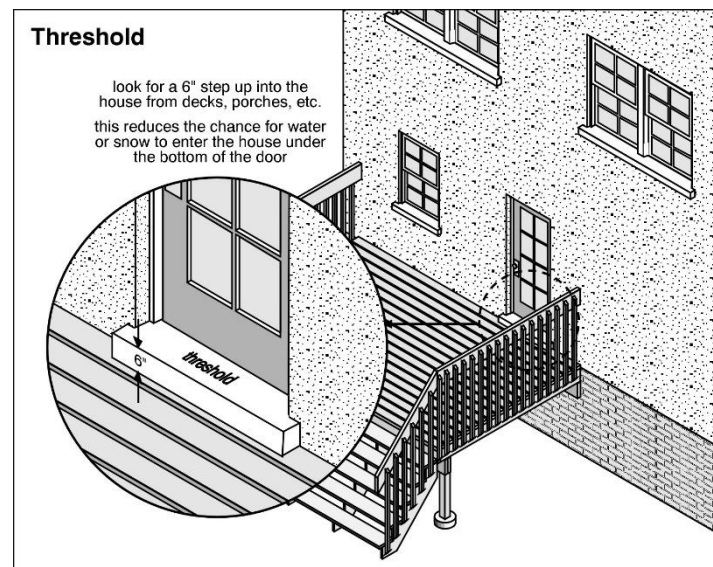

Exposed Foundation Walls: Look for brick, block, mortar and parging that's eroded or cracked. In particular, monitor any cracking caused by settling.

Porches and Decks: Check to see if steps and railings are secure and wooden elements haven't been harmed by rot or insect infestation. To protect wood, periodically re-paint or re-stain

Windows and Doors: Always remember to seasonally install storms and screens in a timely manner and to clean window wells regularly. Inspect for defects in weather-stripping, caulking and for cracked or broken panes of glass. Repair and replace as required. And don't forget to examine finishes—especially sills—for rot and paint deterioration.

Garages: After checking the basic structure for any evident movement, check the roof to see if it's been worn down. Make it your business to clear and test floor drains. All wood should be reviewed for rot or insect infestation, and should be painted or stained according to need. And remember to test your automatic garage door opener at least once a month, adjusting to reverse in the event of emergency.

Driveways and Sidewalks: Preventive measures include checking for cracks, deterioration, uneven areas (a hazard to pedestrians) and settling that allows surface water to slant toward the house and cause damage. The latter two conditions should be attended to quickly.

Retaining Walls and Fences: Insect infestation and rot are two common threats to wooden retaining walls. So be sure to inspect for those two conditions. Whatever the material, though, scrutinize all retaining walls for apparent movement.

Trees, Shrubs and Vines: Cut back and clear all limbs overhanging your house and be sure to remove dead limbs. Vines touching wood surfaces like windows and doors? Trim them.

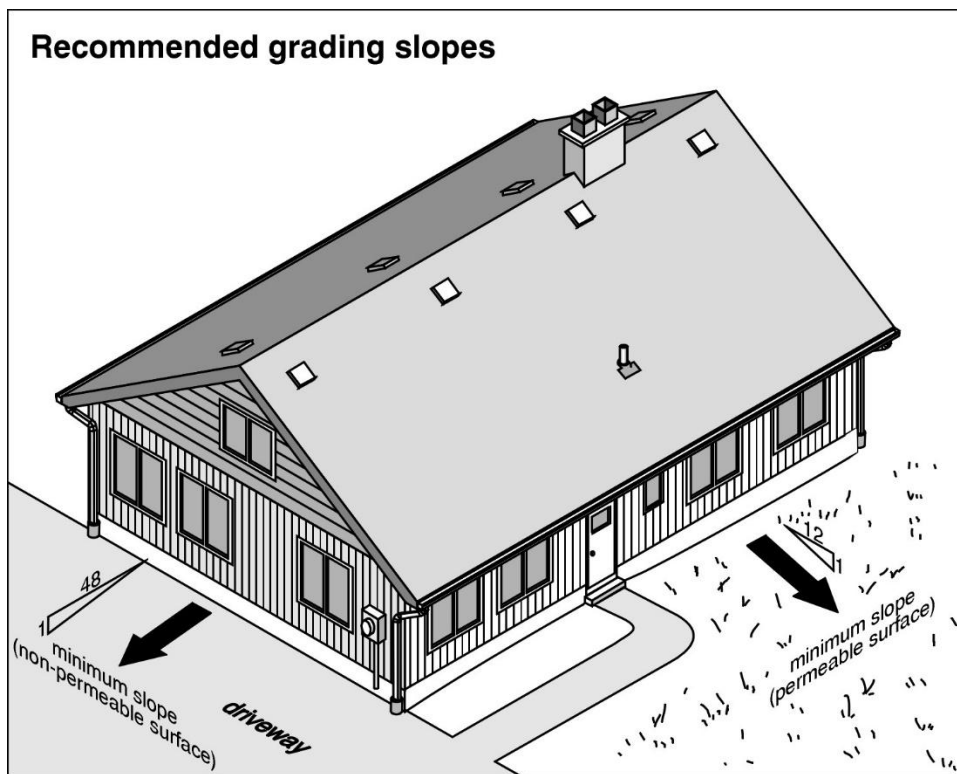

Grading: Scan the first six feet surrounding the house to make sure there's a slope of one inch per square foot. Next clean and test the catch basins.

HEATING AND COOLING

Forced Air Systems: If you have a conventional filter, review it monthly and, if needed, either clean or replace it. Electronic filter? Simply clean monthly, following the manufacturer's instructions. After cleaning, take special care to install interior components in the correct sequence.

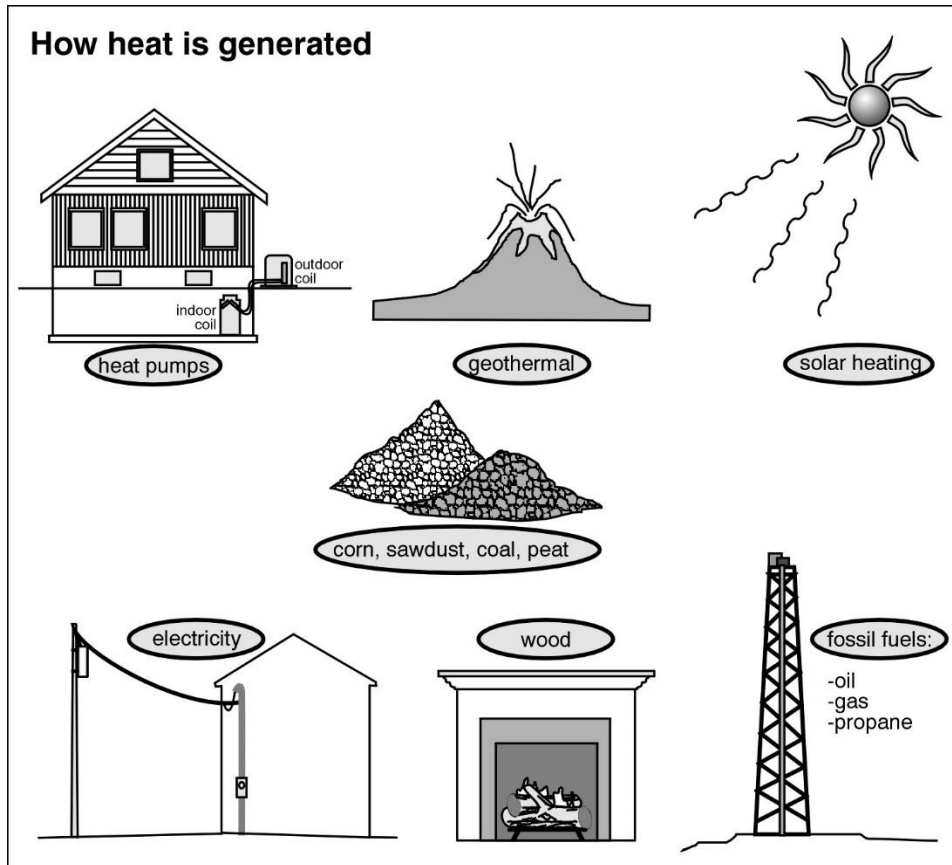

If you have a humidifier- Inspect and adjust the water levels in your humidifier once a month. If you have a drum-type humidifier, replace the pad once a year. Replace interior elements as needed. During summer months, shut off the water supply; and in heating months, activate the supply. If you have a system with air conditioning or a heat pump, close the damper in the humidifier ductwork during cooling season. If your blower system becomes noisy, it's time to call in a professional.

Hot Water Systems:

Twice during the heating system, lubricate circulating pumps. Then, once a year, drain expansion tanks; inspect radiators and convectors for leakage, paying strict attention to

the valves; and bleed the radiators (perhaps an extra time or two during heating season).

Electric Heat: Jobs you may be able to do yourself include: Periodically inspect circuit breakers and fuses; investigate baseboard heaters for safe clearance away from combustible materials; repair or replace mechanically damaged baseboard heaters.

A job you should entrust to a professional: Annual inspection to confirm that all parts are operating efficiently and that no connections are burnt or loose.

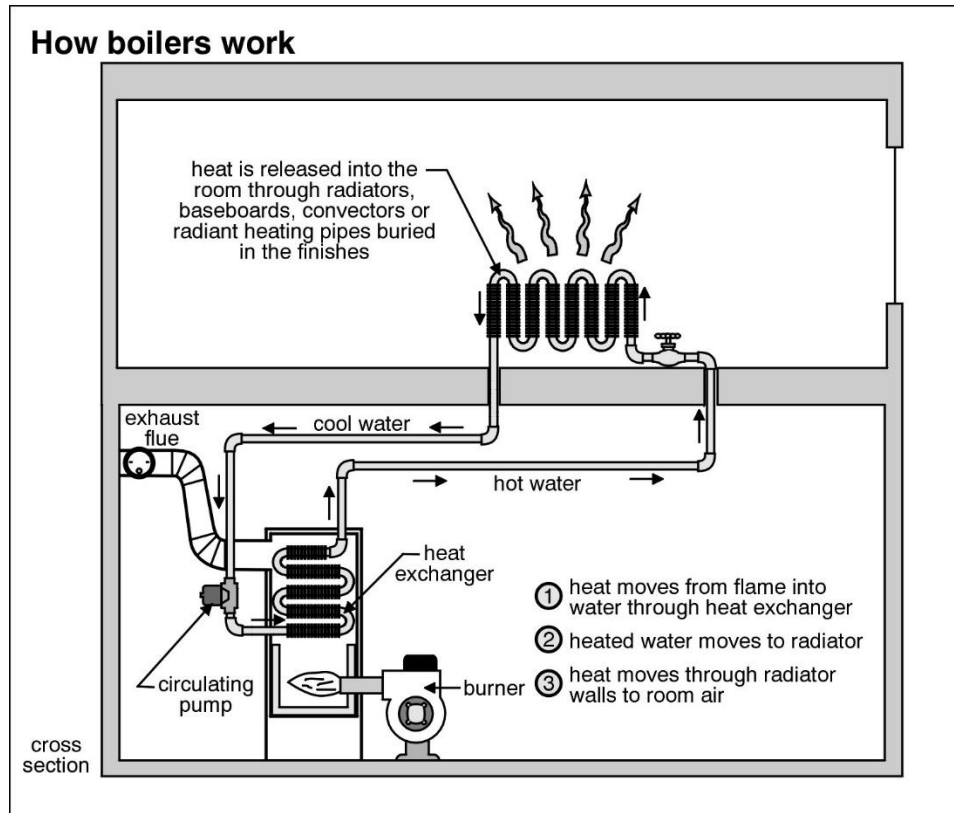

Oil Furnaces and Boilers: Make an exhaustive review as follows: Check for corroded or loose connections in the exhaust pipe leading from the furnace to the boiler. See to it that the barometric damper on the exhaust pipe is rotating freely. Make sure the chimney is cleared of all debris. Scrutinize the oil tank for leaks. To intercept a possible combustion or draft problem, look for soot at the front of the boiler or furnace. To thwart a possible crack in the heat exchange, seek out oily soot deposits at the registers of forced-air systems.

In the latter two cases, call in a technician to deal with the problem. And in any event, schedule a technician for a general inspection annually.

Gas Furnaces and Boilers:

Good maintenance should include the following: annual cleaning and servicing; clearing any debris from chimney clean-out; exhaust pipe and heat-shield check-ups to see that they're not loose or corroded. If burn marks are present on the heat shield, there may be a combustion or draft problem, in which case a technician should be summoned.

Caution: If there's a whiff of gas odor in the air, call the gas company without hesitation. During the waiting period, do not utilize anything with an open flame and do not switch on anything electrical.

Wood Stoves: First, make sure there's always plenty of room between the stove and any combustible materials. Secondly, make sure that flues and chimneys are cleaned and inspected for creosote build-up at least once a year, and more frequently if the stove is heavily used.

If there is any question about the stove's safety, consult with your local municipal building inspector immediately.

Cooling/Heat Pumps: Proper maintenance means you should: inspect refrigerant lines for loose, missing or damaged insulation; clear away vegetation and debris from outdoor components; keep outdoor coil clean; during cooling season, examine condensate drain line (rising from ductwork) above the furnace for leakage; during winter, remove and store window air conditioners indoors.

Two problem areas to be on the lookout for: (1) If the outdoor section heaves or settles and does not stand level, and/or (2) if the fan becomes noisy--denoting a problem with alignment or bearings--call a technician.

Indeed, it's wise to engage a technician annually to inspect the system and, if necessary, recharge it.

ELECTRICAL

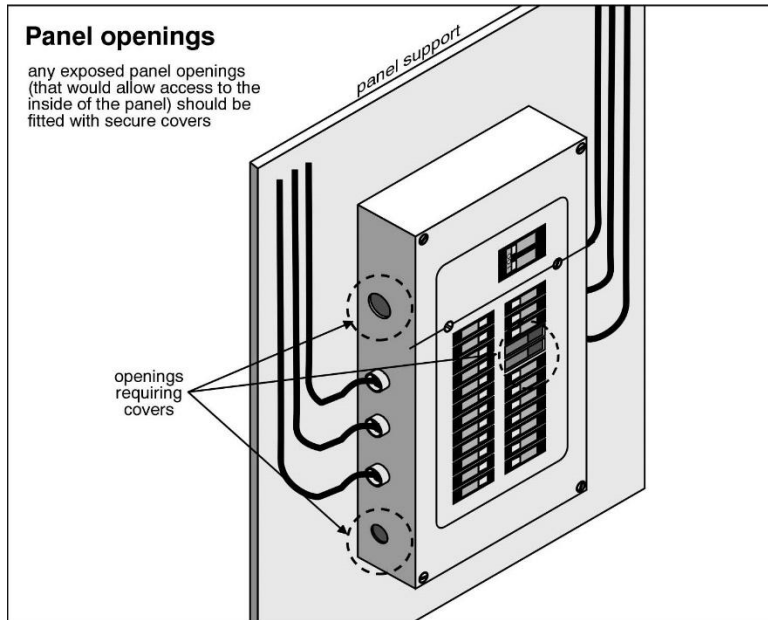

bad connections).

Main Panel: Begin maintenance by making sure that a three-foot radius around the panel contains no storage. Next, label all circuits if you haven't already done so.

Now for inspection procedures: Each and every month, test ground fault circuit interrupters. Once a year, inspect the main electrical panel for rust or water marks (which signify penetration of moisture); turn breakers off and on to be positive that none have seized; tighten all fuses; and have the aluminum wire connections inside the distribution panel tightened by a qualified electrician.

There are two warning signs of imminent danger, both of which should be handled by a qualified electrician: (1) A main panel that gives off the smell of burnt insulation or is warm to the touch, and (2) burnt wires (which are markers for loose or

Indoor Wiring: First off, be sure to replace any and all damaged or frayed wire, such as appliance cords, plugs and extension cords. Next, tighten all loose switches and outlets. Then, every month test ground fault circuit interrupter electrical outlets.

Jobs you should leave for a qualified electrician: (1) Correcting loose or bad connections on exposed wiring in the basement, and (2) annual tightening of all aluminum wire connections in the home.

Outdoor Wiring: First, make sure all exterior outlets are protected by proper covers and—if they're the ordinary kind of outlets—you should probably replace them with GFCI outlets.

Items to inspect: (1) The masthead and wires leading to the street (if overhead), and (2) overhead wiring connecting to out building such as work sheds and garages. Both should be checked for frayed or loose wire.

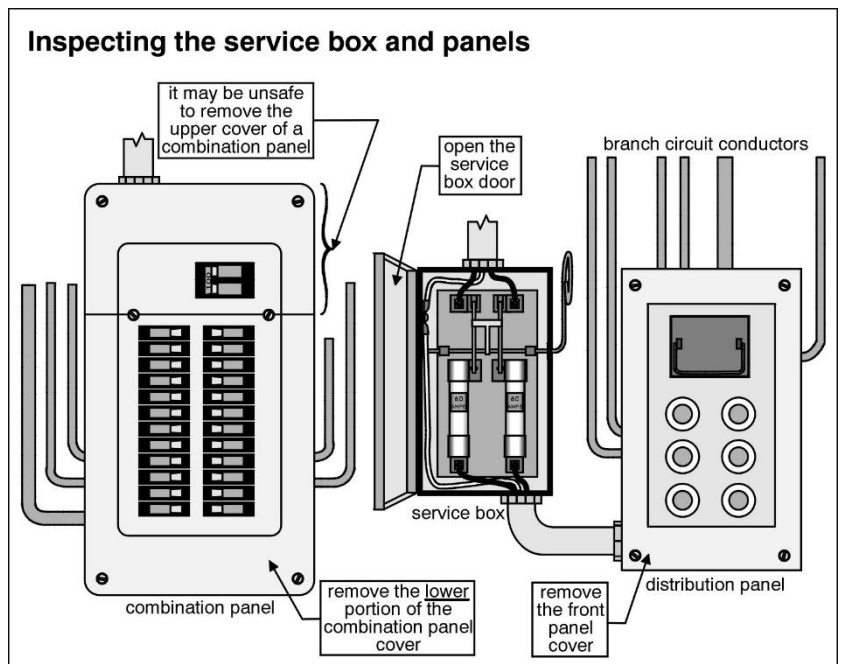

PLUMBING

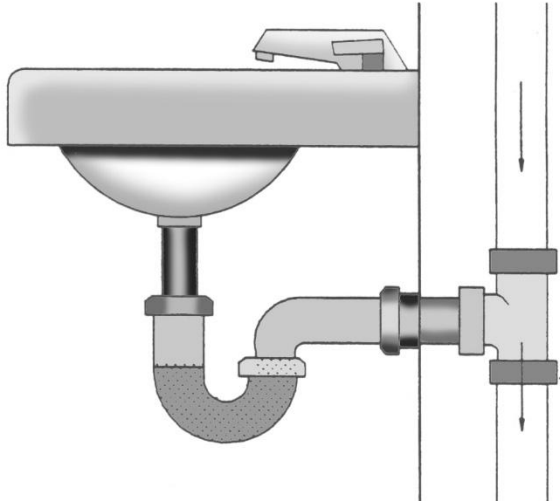

Supply Plumbing: Inspect for leaks annually, and be sure to repair leaking or dripping faucets in a timely manner. Check your well equipment in the spring and fall. Ask your inspector to conduct periodic water-quality tests. From time to time, operate the main shut-off valve and essential isolating valves so that you're positive they'll all work should an emergency arise.

To be prepared from winter's freeze, shut off outdoor faucets from your home's interior and be sure all water has been drained. Also, be careful to guard against freezing in areas such as crawl spaces.

Waste Plumbing: Regular inspection and cleaning of exterior drains, basement floor drains and (annually) septic tanks is a must. And be sure to clear any interior drains that are running slow. Check out visible-waste plumbing for

leaks, too. To be certain that basement-floor drain traps aren't damaged, fill them with water. If they're cracked or there's been water evaporation, you'll know it by the sewer odors drifting up into your home.

Fixtures: Maintain a regular vigil on the following: toilets not firmly secured to the floor; continuously running toilets; crumbling or defective grouting and caulking of bathroom fixtures; improperly functioning sump pumps. If any of these defects turn up, call in a plumber or repair yourself, if you're adequately trained and/or experienced.

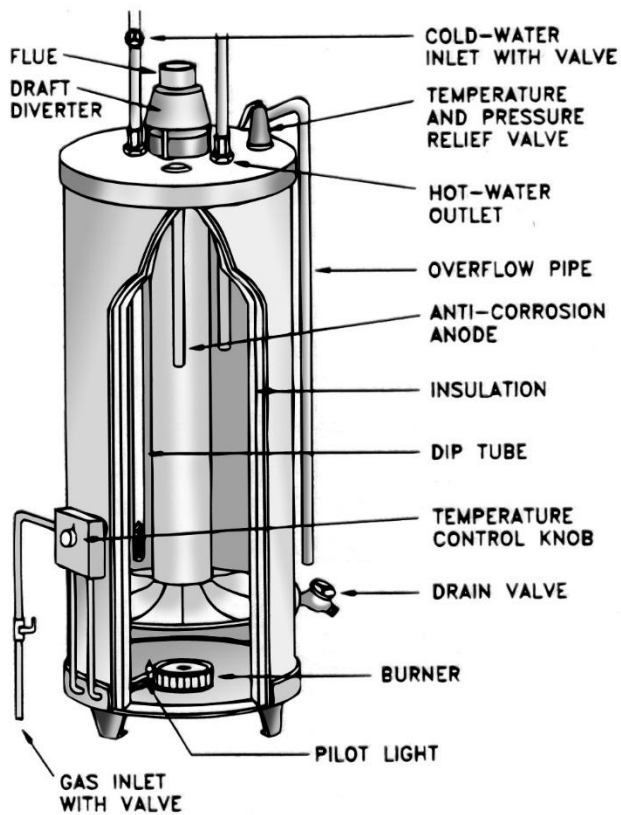

Water Heaters: In some parts of the country the build-up of sludge at the bottom of the tank can be a problem. To test for sludge accumulation, drain some water from the bottom of the tank. If sludge appears, you know that you'll want to start a regular schedule of draining. Before every draining, make sure you've closed off the fuel or power supply.

Every quarter--utilizing the test lever on the pressure relief valve—conduct a test of the valve to determine if there is seizure. In the event that the relief valve doesn't discharge near a drain, use a bucket.

ATTIC

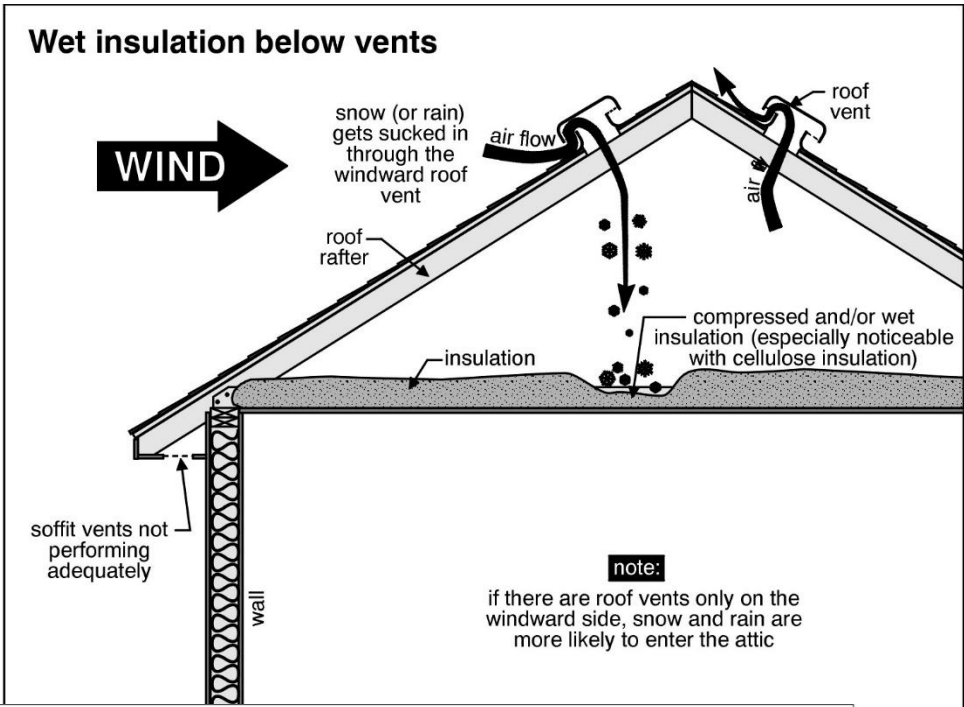

Be certain to inspect your attic annually. Check for mildew, rot, fungus and other signs of excess humidity levels. Investigate the underside of the roof sheathing for water stains. Explore insulation for wetness and make sure it hasn't been blown about by wind or is covering pot lights or that bare spots are present. Peer into vents to be certain insulation or bird nests haven't obstructed them. Search for traces of pest (squirrels, raccoons, etc.) infestation. And review rafters and collar ties for rot and movement.

Recommended amount of attic ventilation

the total vent area is often recommended to be 1/300 of the floor space of the attic

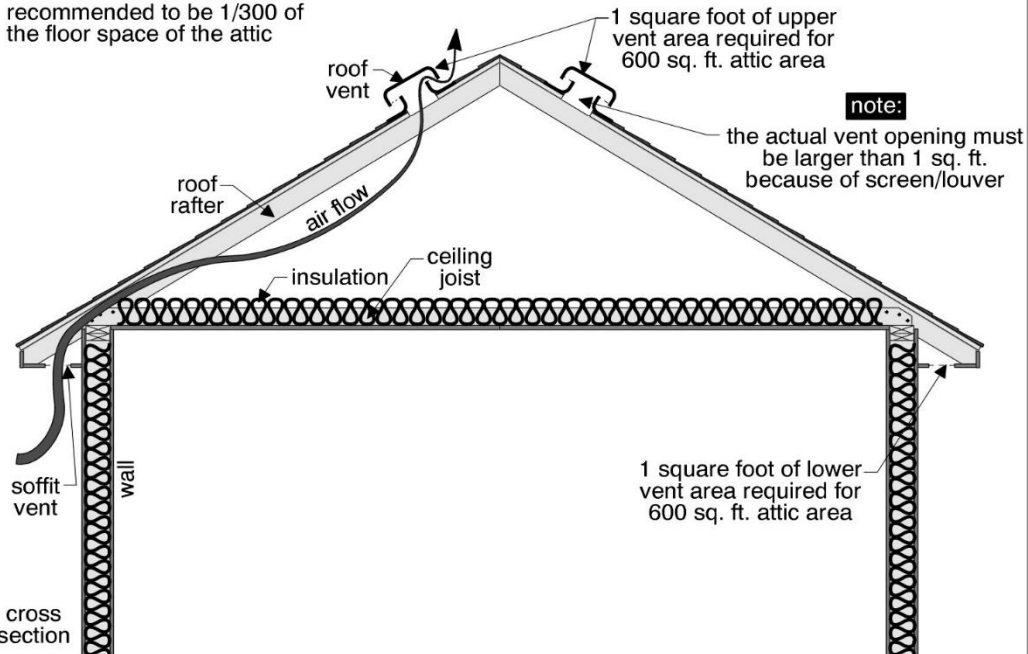

Caution: When exploring your attic on foot, take care not to step on wires or fall through. Also, try to avoid walking on insulation, since it loses some of its insulating properties when it's compressed.

HOUSEHOLD PESTS

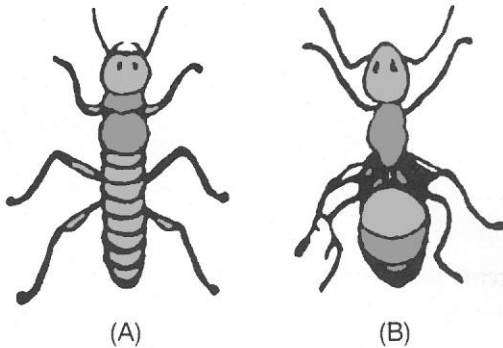

There's a host of creatures that can invade your home, pester you in any number of ways and turn you into their unwilling host. Following are profiles of these pests and hints on what you can do to thwart their ill-mannered advance.

Carpenter Ants: North America's largest ants are usually at their busiest in spring and early summer, when they nest (but do not eat) wood, leaving in their wake telltale saw dust accumulation. You'll find them chomping away and nesting in walls, ceilings, outdoor siding, floors, window casings or in any wood that's wet or rotting. Outdoors, their favorite foods are plant material and other insects; indoors, their favorite foods are the remains of your favorite foods.

Defensive measures: Remove any decayed wood near your home's exterior. Treat with a preservative any wood that's settled in damp areas. Avoid storing firewood indoors for any lengthy period. Store all foods in closed containers. And if you should accidentally spill some sugar, flour, etc., clean it up quickly and thoroughly.

If infestation persists, call in reliable pest-control experts who'll apply proven chemical-control techniques.

Earwigs: One of the most prevalent and persistent pests around, these nocturnal invaders are found in homes and gardens, gobbling up both plant and animal food and in the process damaging fruits, vegetables and flowers.

Defensive measures: During June or early July, apply chemical treatment around fences, wood piles, garages, tree trunks and building foundations. And don't forget under your porches. Be forewarned, though. Treatment notwithstanding, these resilient marauders can return—again in large numbers-- in as little a while as two weeks.

Silverfish: Nocturnal by nature, these decidedly unattractive pests feel at home in dark, damp, warm areas of your home--like furnace rooms. They delight in engorging starchy materials like sizing, glue and wallpaper paste as well as crumbs and other human food. They've even been known to feast on paper and other wood by-products.

Defensive measures: Thoroughly vacuum all areas you suspect might be welcoming habitat for silverfish. Avoid letting old books, newspapers, etc. linger in unventilated areas for lengthy periods. Want to trap them? Extend a jarring invitation to them. First, cover the outside of the jar with masking tape so they can gain purchase in crawling up into the jar. Then pour some water into the jar. Once they've entered, the interior glass surface will render futile any attempts to climb back out.

If your silverfish problem continues to spread, employ a chemical control solution.

Anobid Beetles

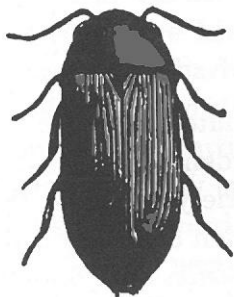

Old House Borer

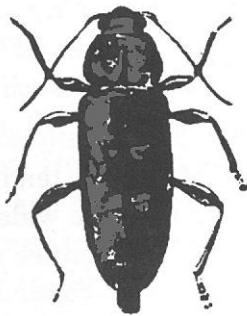

Cockroaches: Perhaps the most dreaded of pests, the cockroach comes in a variety of species and voraciously gobbles just about anything—human food, plants, paper, glue, you name it. Most comfortable in damp, dark places, the roach can be a carrier of the dangerous salmonella bacteria.

Defensive measures: **With a reputation for being the most challenging bug to get rid of, the cockroach thrives in homes where housekeeping standards are less than exact. So make sure all food is kept in closed containers and that spills are promptly and completely cleared. If it's feasible, remove the sources of dampness in your home.**

If they won't leave, have them chemically evicted by a trained professional.

Sowbugs: Though they hardly ever cause severe harm to households, these members of the crustacean family-- who prefer living in dark, damp neighborhoods such as basement corners—like dining on decaying organic matter and occasionally on wet, rotted wood. **Defensive measures: Simply keep your basement as dry and well ventilated as possible.**

Termites: Dwelling in the soil below the house, these most destructive of creatures nonetheless invade the house to gorge on wood—especially damp and rotting wood, but sound, dry lumber as well. Though the considerable wood damage termite's cause is seldom noticeable at first, there is a way to detect their presence. If direct soil-to-wood contact doesn't exist, termite armies build shelter tubes or tunnels --up to 1/2" in width and composed of soil-- leading up to the house.

Defensive measures: At first sighting of the shelter tubes, call a pest control company *post haste* and have them apply a chemical resolution to the infestation. In fact, consulting with the company, it would be a good idea to book regularly scheduled termite inspections. Another key measure: Be vigilant about keeping soil from contacting wood components of your home.

Note: In some parts of the country, government assistance in chemical control is available.

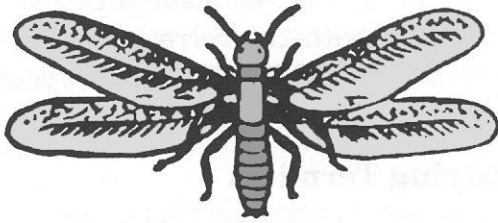

(A)

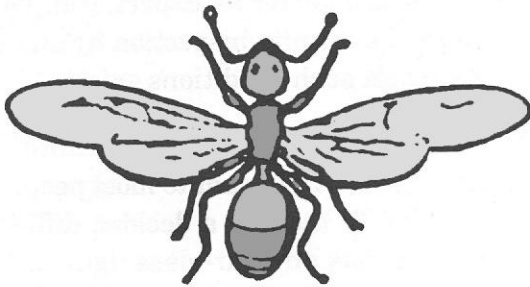

(B)

FLEAS: THESE ITCH-INDUCING PESTS ENTER THE HOME ABOARD THE ANIMALS ON WHOSE BLOOD THEY THRIVE ON—DOGS, SQUIRRELS AND—THE MOST TROUBLESOME FOR HUMANS—CATS. THOUGH THEY MOSTLY NEST ON THEIR HOSTS, FLEAS WILL FROM TIME TO TIME JUMP ONTO OTHER SPECIES—INCLUDING HUMANS—SEARCHING FOR FOOD IN WHAT AMOUNTS TO A SHORT, TEMPORARY STAY.

DEFENSIVE MEASURES: ALBEIT ADULT FLEAS AREN'T DIFFICULT TO EXTERMINATE, THE LARVAE—NESTLED IN UNUSUALLY SECURE COCOONS--ARE. YOU CAN TRY ONE OF THE COMMERCIAL CONTROL PRODUCTS WIDELY STOCKED BY RETAILERS, BUT IT'S PROBABLY WISEST TO HIRE A PROFESSIONAL EXTERMINATOR.

Mice: Talk about prolific! During a typical female house mouse's one-year life expectancy, she can give birth to as many as eight litters of 4 or 5. While mice chew and digest just about anything humans do, they tend to favor grain and seed. Able to survive on very little water, these very little vermin establish territory in a radius of about 30 feet from their nests. Because they keep their teeth sharp by gnawing on anything available, they puncture and damage wood, asphalt, mortar and even aluminum. Worst of all, these swift nocturnal creatures can escape danger by slipping through holes as tiny as one-half inch in diameter.

Defensive measures: First and foremost, to keep mice out of the house and away from temptation, high sanitation criteria are a must. So, store all foods in tightly closed containers mice can't chew through, thoroughly and quickly clean up any spills, and keep floors, tables and countertops free of all food particles.

Once mice have arrived, you can exterminate them by trapping or poison. Spring traps or glue traps can be baited with peanut butter, cheese, bacon or bread. Poisons should be handled with great care and positioned in places where children and pets can't reach them. It usually takes a few days of ingestion for any of the poisons to work. Remember to store unused poison in out-of-reach places and to mark the container "DANGER: POISON."

After mice are no longer alive, quickly and safely get rid of them.

Raccoons: The crafty, nocturnal omnivores make meals of fish, meat, nuts, grain, vegetable and fruit. Thus, they've become adept and widespread urban garbage pickers.

Defensive measures: To put it succinctly, **BLOCK ENTRY!** Keep garage doors shut. Keep garbage in tight, heavy containers that can't be easily toppled. Cover chimney flues with sturdy screens. Cut back tree limbs near the house. Shield TV towers and trees with screens to block access to roofs. If you want to rid yourself of a raccoon that persists in hanging around the house, humane traps can be used to cage and remove the animal to a remote region that's safer for both you and the raccoon. Since we don't recommend trapping the raccoon by yourself, the only trapping instruction we provide is as follows: Call in a professional.

NOTE: A-Pro provides the information above to attempt to inform new homebuyers about general home maintenance. The maintenance suggestions listed above are by no means a complete list of items that need maintenance in a home. These statements above are only a compilation of maintenance suggestions based on our experience in the business of property management, home ownership and inspection.



**IT TAKES A-PRO TO KNOW...
DON'T BUY A HOME WITHOUT US!**